

Service Manual

for

MODEL S-2500/S-2500C
SCANNING ELECTRON
MICROSCOPE

Part No. 48E-8005
YK-F (HYK-LT)

CONTENTS

1. INFORMATION REGARDING SAFETY
2. INSTALLATION INFORMATION
3. TECHNICAL INFORMATION
4. SERVICE INFORMATION

CONTENTS

1. INFORMATION REGARDING SAFETY	1-1
1-1 Precautions for Transport	1-1
1-2 Precautions for Power Connection	1-1
1-3 Precaution for Vacuum	1-2
1-4 Precautions for Hot Parts	1-2
1-5 Precaution on Scintillator	1-2
1-6 Precaution for Fire	1-2
1-7 Precaution for Soldering	1-2
1-8 Precautions on Photomultiplier Tube	1-2

1. INFORMATION REGARDING SAFETY

Be sure to observe the following precautions on handling the instrument in order to ensure safety.

1-1 Precautions for Transport

- (1) Do not lift the display unit and main console by the table since the strength of table fitting is not sufficient for bearing their weight. Should the table be lifted, the table might slip off and the instrument might crash. Hence, it is recommended to remove the table from the microscope column and avoid exerting force on the table of the display unit when transporting them.

Never hold the evacuation pipe, secondary electron detector or objective lens movable aperture of the main unit when transporting it.

- (2) The housing supports should be fitted in place before transport.

1-2 Precautions for Power Connection

- (1) Be sure to turn off the EVAC POWER and DISPLAY POWER switches before removing the front and rear covers of the main console and display unit.

- (2) Connect the grounding wire correctly. Otherwise, not only will the instrument fail to operate normally but there is a shock hazard.

- (3) Handling of high voltage unit

The following parts are at high voltage. Utmost care must be taken in handling them.

- High voltage transformer : Maximum output 30 kV
- CRT post 10 kV unit : Maximum output 10 kV
- VIDEO AMP circuit board pattern wiring : Maximum output 650 V
- CRT : 10 kV
- Secondary electron detector : 10 kV
- Out-lens detector bias : 150 V

- (4) Be sure to cut off the main switch of the switchboard when replacing a fuse.

- (5) When replacing the scintillator, turn off the DISPLAY switch without fail.

- (6) Allow an interval of at least 5 seconds between ON/OFF settings of the DISPLAY switch. If the switch is turned on/off in quick succession, the CRT might be burned since its heater remains hot.

1-3 Precaution for Vacuum

- (1) Before measuring vacuum with a Geissler tube, turn off the EVAC POWER switch. Otherwise, the evacuation sequence might malfunction due to discharge wave.

1-4 Precautions for Hot Parts

- (1) The following parts heat up to a temperature of 55° C or higher in normal operating status.
 - (a) Oil diffusion pump
 - (b) Oil rotary pump
 - (c) Heat radiating plate at rear of power unit
 - (d) Capacitor top tube

1-5 Precaution on Scintillator

Never touch the surface of the scintillator nor direct a Freon gas spray on the like toward it.

1-6 Precaution for Fire

When using an organic solvent for cleaning, avoid placing it on the main console or display table. If its container is tipped over, it might ignite due to heat of the diffusion pump.

1-7 Precaution for Soldering

Never shake the tip of a soldering iron above a circuit board. Otherwise, soldering material might drop onto the board and cause a short-circuit.

1-8 Precautions on Photomultiplier Tube

- (1) Protect the photomultiplier tube from light even when it is not energized, otherwise excessive noise might occur.
- (2) The photomultiplier tube and CRT must be protected against external shocks, otherwise they might be damaged.

CONTENTS

2. INSTALLATION INFORMATION	2-1
2-1 Unpacking and Bringing in Instrument	2-1
2-1-1 Removal of Wood Frames for Transport	2-1
2-1-2 Bringing in	2-1
2-1-3 Unpacking	2-1
2-1-4 Parts Check	2-2
2-2 Installation	2-2
2-2-1 Installation Requirements	2-2
2-2-2 Installation Layout	2-7
2-3 Assembling and Wiring	2-8
2-3-1 Assembling Microscope Column	2-8
2-3-2 Adjustment of Oil Diffusion Pump Retaining Bolts	2-9
2-3-3 Wiring between Display Unit and Column	2-10
2-3-4 Arrangement and Dismounting Procedure of Display Unit Components	2-11
2-3-5 Check after Assembling	2-13
2-4 Installation of Model S-5704 Mode/Dual Mag. Control Unit	2-14

2. INSTALLATION INFORMATION

2-1 Unpacking and Bringing in Instrument

2-1-1 Removal of Wood Frames for Transport

- (1) Remove the top frame (1-piece) and the side frame (4-piece).
- (2) Remove the wood blocks for transport from the bottom frame (1-piece).

2-1-2 Bringing in

- (1) Main unit
The main unit (column, evacuation system and console) must be transported manually or with a fork lift up to the installation room while carefully protecting it from excessive shocks and vibrations. For system layout, refer to the instruction manual.
- (2) Display unit
The display unit must be transported with reference to (1) above.
- (3) Other parts
Parts other than the main and display units are all accommodated in a cardboard box. Transport the box to the installation room. Confirm that the top of the box is facing up since some of the parts contained might be adversely affected when positioned upside down. Excessive shocks and vibrations must be avoided the same as in (1) above.

2-1-3 Unpacking

- (1) Main unit
Remove all vinyl covers for transport while carefully preventing dust from adhering to the unit.
- (2) Display unit
Connectors for wiring to each section are tied to the chassis for transport. Untie them.
- (3) Other parts
 - (a) Take out all the parts from the cardboard box. After taken out, they must be handled as follows.
 - (b) Larger parts such as oil rotary pump must be placed directly on the floor in a proper order.
 - (c) Lay a soft sheet on the floor and place smaller and delicate parts on it in a proper order.

2-1-4 Parts Check

When all components have been brought into the installation room and unpacked according to 2-1-1 through 2-1-3, personnel in charge of installation must check their quantity against the packing list.

2-2 INSTALLATION

2-2-1 Installation Requirements

(1) General

For installing the Model S-2500/S-2500C, the locations and conditions mentioned below must be avoided.

- (a) Room located in the vicinity of transformer substation
- (b) Room located in the vicinity of elevator
- (c) Location near electric equipment consuming a large power (e.g., electric furnace) or its power supply
- (d) Location near spark discharge source or high-frequency apparatus
- (e) Room filled with gas which corrodes metals, etc.
- (f) Place exposed to direct sunlight or strong draft
- (g) Dusty place
- (h) Location subjected to severe vibrations
- (i) Shared use of ground wire with other electrical equipment
- (j) Location adjacent to radio or sound wave source

(2) Room Temperature and Humidity

- (a) Room temperature 15 to 30°C

Temperature fluctuation should preferably be less than 5°C during operation of the instrument.

- (b) Humidity 70 % or less

The instrument should desirably be operated in air-conditioned room.

(3) Line Power Requirements

- (a) Single-phase 200 to 240 V AC, 3 kVA, 50/60 Hz (for main unit)
Single-phase 200 to 240 V AC, 2 kVA, 50/60 Hz (for optional accessory)
Continuous energization is unnecessary, and allowable line power fluctuation is ± 10 % max.

(Note) Line power fluctuation should be slow, and no abrupt fluctuation is allowable.

- (b) The main console should be located within 10 m of the switchboard on the wall (since input AC cord is only 10 m long).
- (c) Be sure to feed power through an exclusive switch (circuit breaker with leakage alarm on the switchboard is recommended).

(4) Grounding

It is recommended to ground the instrument at a grounding resistance lower than 100 ohms. The grounding terminal should not be shared with other electrical equipment. An independent grounding is required.

(5) Water Supply/Drain

Water should be supplied under the following conditions:

- Flow rate : 1.0 to 1.5 L/minute
- Water pressure : 0.5 to 1 kg/cm²
- Water temperature : 10 to 20°C

Be sure to observe the flow rate and water temperature ranges indicated above. It is recommended to use a circulating constant-temperature bath with quality water having low residual chlorine concentration (0.5 ppm or less).

When using city water, check that its residual chlorine concentration is 0.5 ppm or less and provide natural drainage.

(The specified flow rate and water temperature ranges should be satisfied throughout year.)

Use a filter if water contains much deposit or fur. The drain port should be equipped at the floor level, and the water pressure should involve no abrupt pulsation. Prepare a dedicated chemical water tap with a flow rate adjust valve.

(6) Stray Magnetic Field

When the stray magnetic field measured at the installation site before introducing the instrument complies with the requirements given in Table 2-1, image trouble will not occur.

Avoid locations where an abrupt electric current change or magnetic field change might occur due to a large-sized magnetic clutch or power cable for other equipment.

Table 2-1 Stray Magnetic Field

	DC Component *1	AC Components *2		
		Same Frequency Component as That of AC Line Supplied to Model S-2500/S-2500C		Different Frequency Component from That of AC Power Supply Used in S-2500/S-2500C
		Observation	Scanning in Synchronization with Power Supply	Scanning Not in Synchronization with Power Supply
		Photographing	All SCAN SPEED Settings	
Maximum allowable magnitude	50 mG max.	3 mG max.	0.05 mG max. *3	0.05 mG max.
Maximum allowable fluctuation *4	1 mG/5 min max.	1 mG/5 min max.	0.3 mG/5 min max.	0.3 mG/5 min max.

mG: Milligauss

- (Notes)
- *1. The components due to terrestrial magnetic field are excluded from the values.
 - *2. All values of AC components are effective values.
 - *3. A magnitude of less than 2 mG constitutes no serious trouble in brightness-modulated image observation.
 - *4. AC and DC stray magnetic field fluctuation is defined as varying monotonously and gradually with time. Thus, magnetic field fluctuation with pulse or step waveform should not occur.

(7) Vibration

When the floor vibration measured at the installation site before introducing the instrument complies with the requirements given in Table 2-2, image trouble will not occur.

If the instrument is installed on the first floor in a building made of reinforced concrete, the instrument performance will not be degraded by external vibrations so long as vibration sources such as machine tools or transportation facilities (electric car, for example) are not operated nearby.

Table 2-2 Allowable Vibration

External vibration: No image trouble will take place if the following conditions are satisfied.

Frequency	Amplitude
5 Hz	3 μ mp-p max.
10 Hz	5 μ mp-p max.
50 Hz	7 μ mp-p max.

- (Notes)
1. With respect to low frequency vibration (*) of 5 Hz or less, a sufficient effect cannot be obtained with the present vibration eliminating (vibration preventive) techniques.
In order to obtain the maximum performance (resolution, magnification, etc.) from the instrument, it is necessary to reduce the amplitude of vibration (to 0.6 μ mp-p or less) at 5 Hz or below.
 2. For the 5 to 50 Hz range, carry out interpolation on the allowable values via connecting lines.
In the range above 50 Hz, it will be within the allowable value for 50 Hz.
 3. If there is floor vibration exceeding the allowable value (vibration should be measured in advance if it is expected to cause a disturbance), then consult with the local Hitachi service agent.

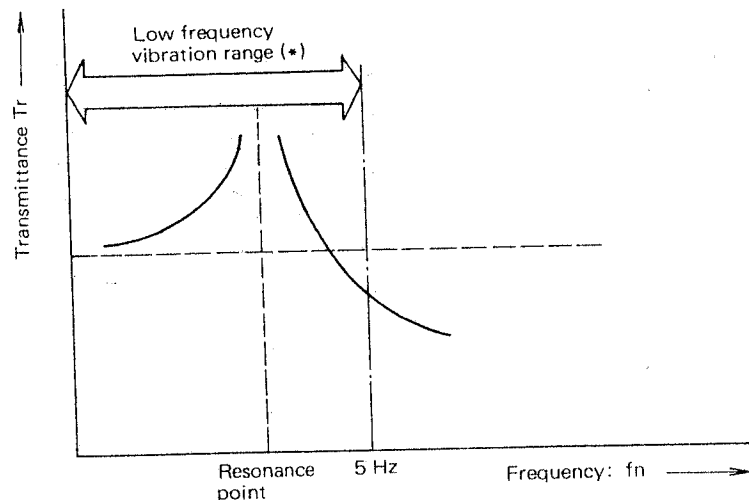

(8) External Noise

If any equipment shown in Table 2-3 or its power line is placed in the vicinity of the Model S-2500/S-2500C, or if an equipment carrying a large current is located even at a distance, then image trouble will occur. To prevent this, the installation site should be selected after confirming that such equipments do not exist.

If an equipment which uses a power frequency differing from the line frequency used for the S-2500/S-2500C, or the power line of such equipment, is placed near the S-2500/S-2500C, the power frequency-synchronized scan becomes ineffective. Such a location should be avoided.

Table 2-3 External Noise Source

Classification		Noise Source	Source Equipment
Small-sized electric equipments (general/home electrical appliances)	Electric equipment with contacts	Electric discharge (spark, arc)	Flasher (neon sign, ornamental electric bulb), relay, electromagnetic conductor, thermostat (warmer, refrigerator, iron), electronic calculator, cash register
	Equipment utilizing commutator motor	Electric discharge (spark, arc), sliding contact	Electric drill, laboratory engine, motor of sewing machine, cleaner, mixer, shaver, massaging machine
	Electric discharge tube	Glow discharge	Neon discharge tube, high pressure mercury arc lamp
	Controller utilizing semiconductor	Phase control (transient noise)	Thyristor dimmer, inverter
Equipment using high frequency	Industrial high frequency equipment	Unnecessary signal*	Industrial high frequency heater, high frequency electric welder, electronic oven
	Medical high frequency equipment	Unnecessary signal*	VHF/UHF fulgurators, electric scalpel
	Equipment utilizing ultrasonic wave	Unnecessary signal*	Flaw detector, depth sounder, fishfinder, ultrasonic cleaner
Power equipment	Power cable (transmission line)	High voltage, large current	Induction of commercial frequency (electrostatic induction, electromagnetic induction, current leaking in ground)
		Electric discharge (corona, arc)	Corona, poor insulator, poor contact due to corroded metal (arc discharge)
	Electric car	Electric discharge (spark, arc)	Trolley wire, internal equipment, rectifier
		Reflection	From car body

Classification		Noise Source	Source Equipment
Internal combustion engine	Automobile	Electric discharge	Ignition system
		Other	Dynamo, voltage regulator, wiper, horn, winker
Wireless communication	Wireless sending/receiving equipment	Signal radiation*	Broadcasting equipment, radar, wireless sending/receiving equipment
		Unnecessary radiation	Transmitter using higher harmonics

(Note) The signal marked "*" is used normally in the relevant system, but becomes a disturbance for other systems.

(9) Disturbance by Sound Wave

Sound waves (vibrations of air) adversely affect the S-2500/S-2500C regardless of their frequency and may cause image trouble.

To prevent this, confirm before installation that an equipment which may cause a sonic disturbance is not located in the vicinity of the S-2500/S-2500C.

If such equipments exist, then check for noise level.

When conversation is possible in a usual voice around the installation site, the noise level is allowable. But if conversation is possible only in a loud voice due to abnormal noise of the equipment, sonic disturbance may occur.

(10) Site Requirements

(a) Space required

A room of about 2.8 m × 2.8 m or more is recommended.

(Minimum space: 2.6 m × 2.6 m)

(b) Dimensions of entrance

0.92 (W) m × 1.7 (H) m at minimum

(c) Durability of floor

$$\frac{\text{Floor strength (kg/m}^2\text{)}}{3} \geq \frac{\text{Total weight of instruments installed in the room (kg)}}{\text{Floor area of the room (m}^2\text{)}}$$

(d) Others

- Sliding blackout curtains around the instrument are convenient.
- Dark room for film D.P.E. is also convenient.
- See Fig. 2-1 for installation layout.

2-2-2 Installation Layout

Install the instrument system as shown below.

* The cooling unit is not used for Model S-2500C

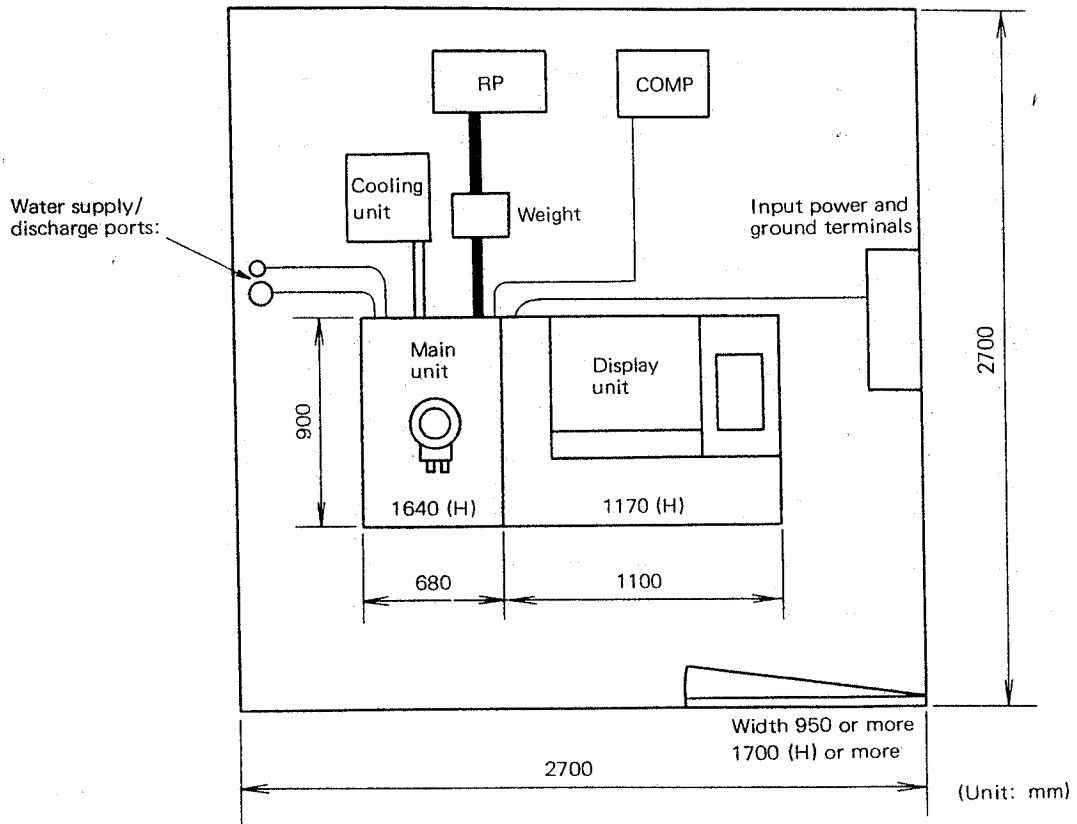

- RP 230 x 500 x 450 (H)
- COMP 230 x 390 x 560 (H)
- Cooling unit 320 x 350 x 320 (H)

Fig. 2-1 Installation Layout

2-3 Assembling and Wiring

2-3-1 Assembling Microscope Column

Proceed as follows.

- ① Remove the retaining bolts for transport.
- ② Connect the city water hose for cooling.
- ③ Connect the rubber tube and discharge tube.
- ④ Connect the RP oil filter.
- ⑤ Connect the air compressor.
- ⑥ Connect hose to the cooling unit and fill it with coolant. (Except for S-2500C)
- ⑦ Connect the cord.

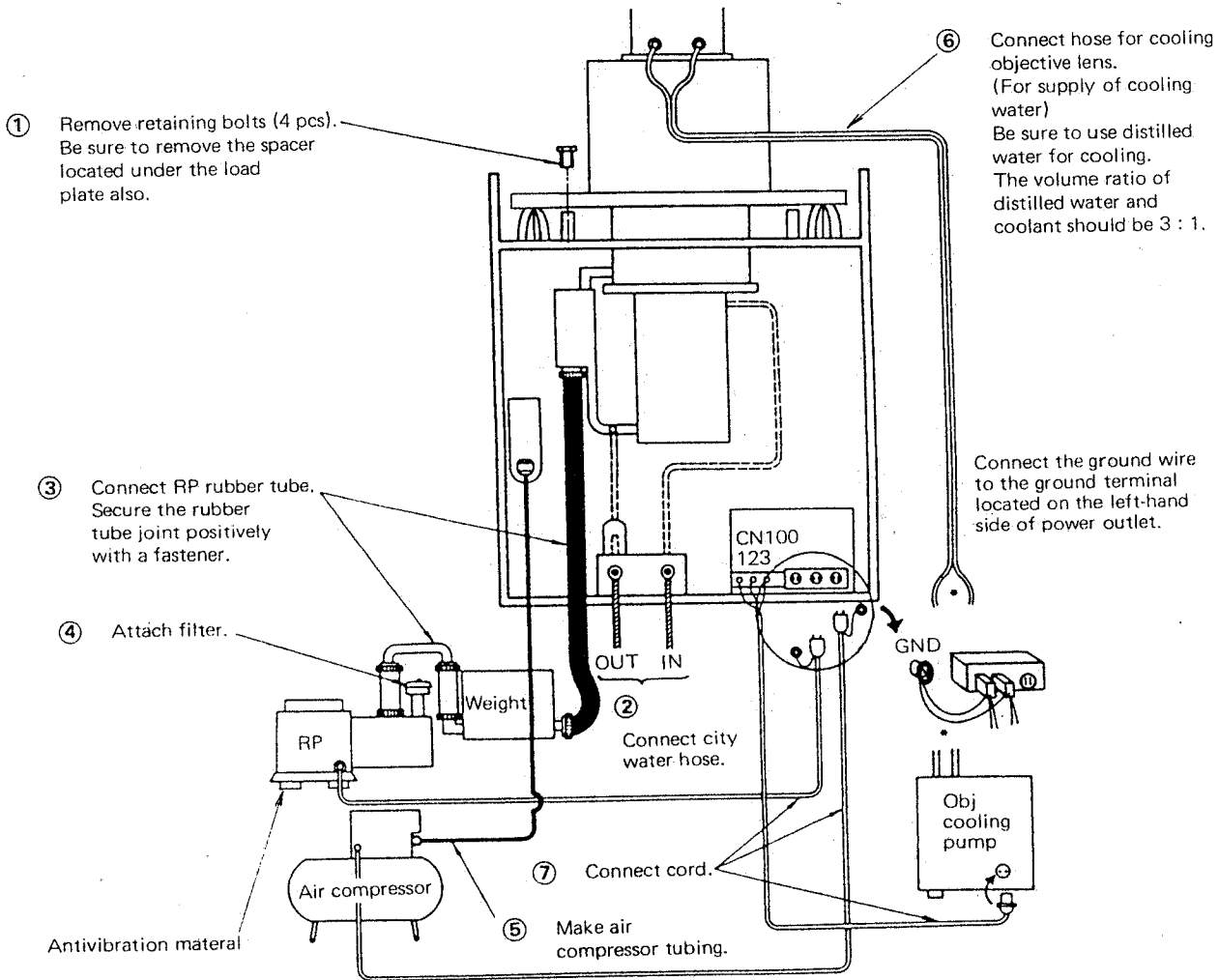
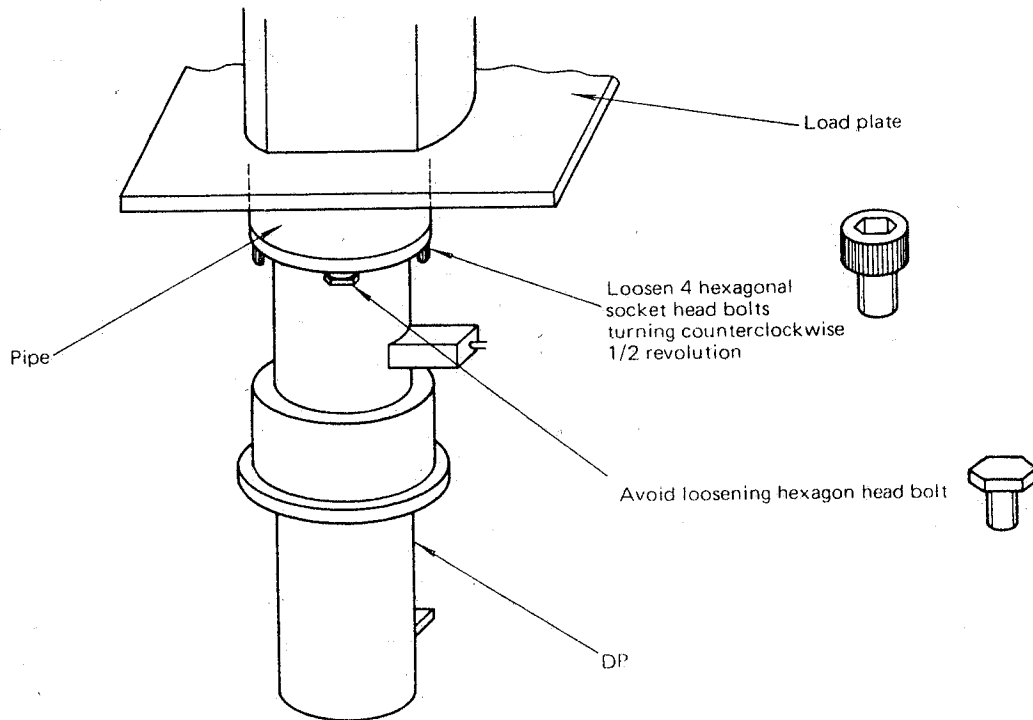

Fig. 2-2 Assembling Microscope Column

2-3-2 Adjustment of Oil Diffusion Pump Retaining Bolts

Loosen the bolts (M10, hexagonal socket head) shown below in order to prevent vibrations being transmitted from the oil diffusion pump to the upper sections. This will provide a clearance of about 0.5 mm between the load plate and pipe.



The bolts must be tightened when transporting the instrument.

2-3-3 Wiring between Display Unit and Column

The connecting cords are listed in the table below. They have been shipped from the factory with either end connected (parenthesized in the table).

No.	CN No.	Cord	Display Side	Column Side
1	CN26	Head amp cord	VA circuit board CN26	(SE detector)
2	UPPER	Post HV cord	(HV tank)	SE detector
3	LOWER	Post HV cord	(HV tank)	SE detector
4		HV cable	HV tank	(Electron gun)
5	CN13	Deflection coil, etc.	(DEF circuit board)	CDTB circuit board
6	CN39	Gun alignment, etc.	(ALG unit)	CDTB circuit board
7	CN100	100 V AC power cord	(PS-SUB circuit board)	Evacuation system power supply
8	CN110	Vacuum link signal cord	(PS-SUB circuit board)	Evacuation system power supply
9	GUN GND	Grounding wire	(HV tank)	Electron gun section
10	GND	Grounding wire	(Top face of console)	Load plate
11	GND	Grounding wire	(Side face of console)	Rear face of console
12	BIAS	BNC BIAS cord	VA circuit board BIAS	(SE detector)

* No. 2: Except for Model S-2500C

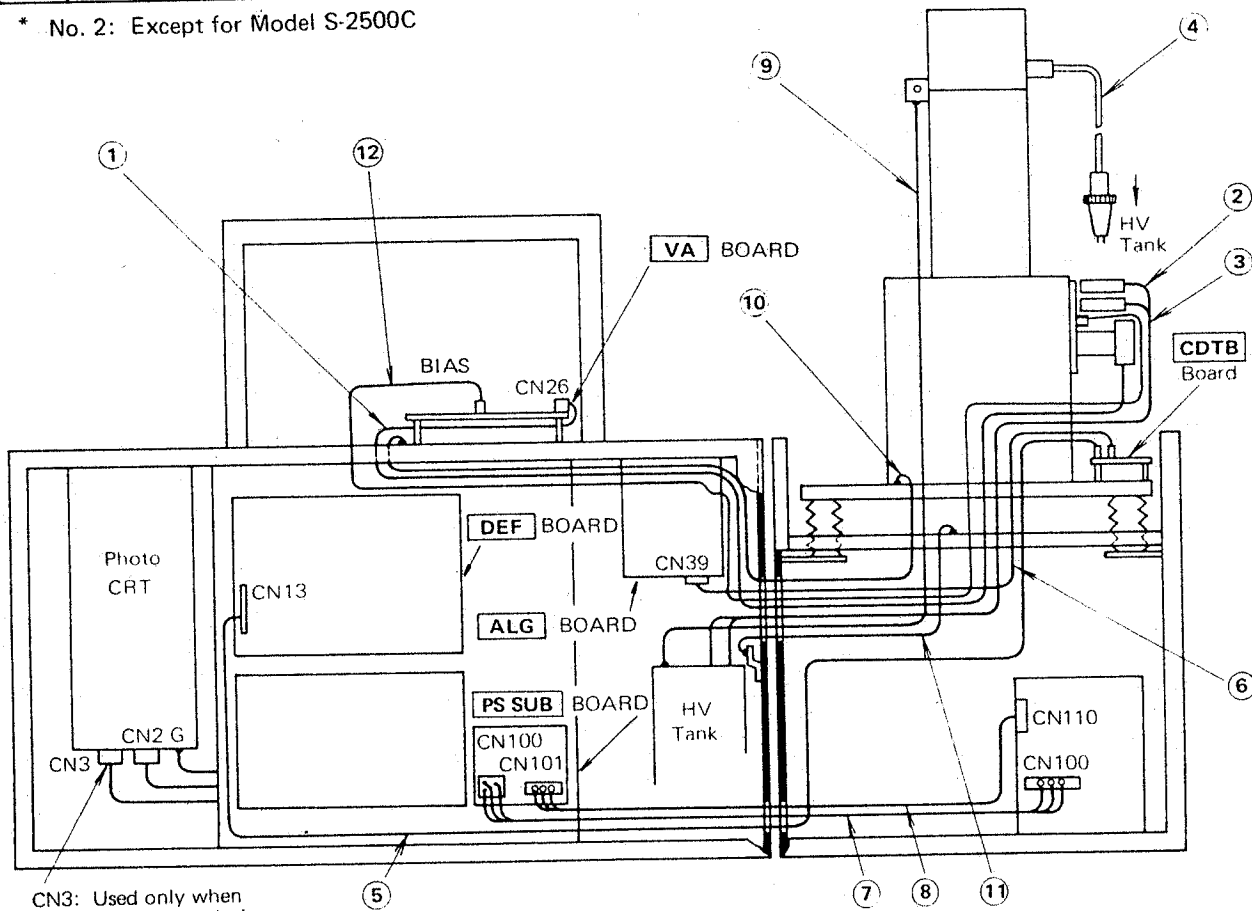
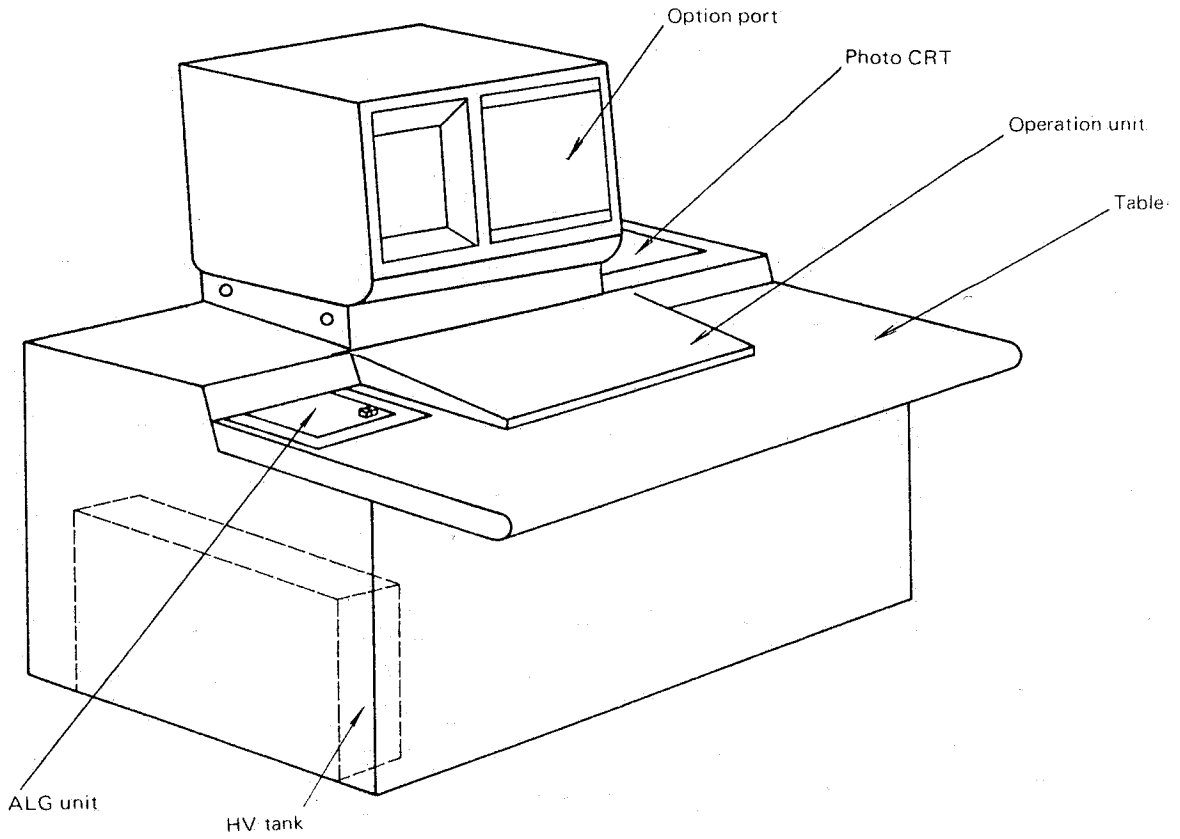
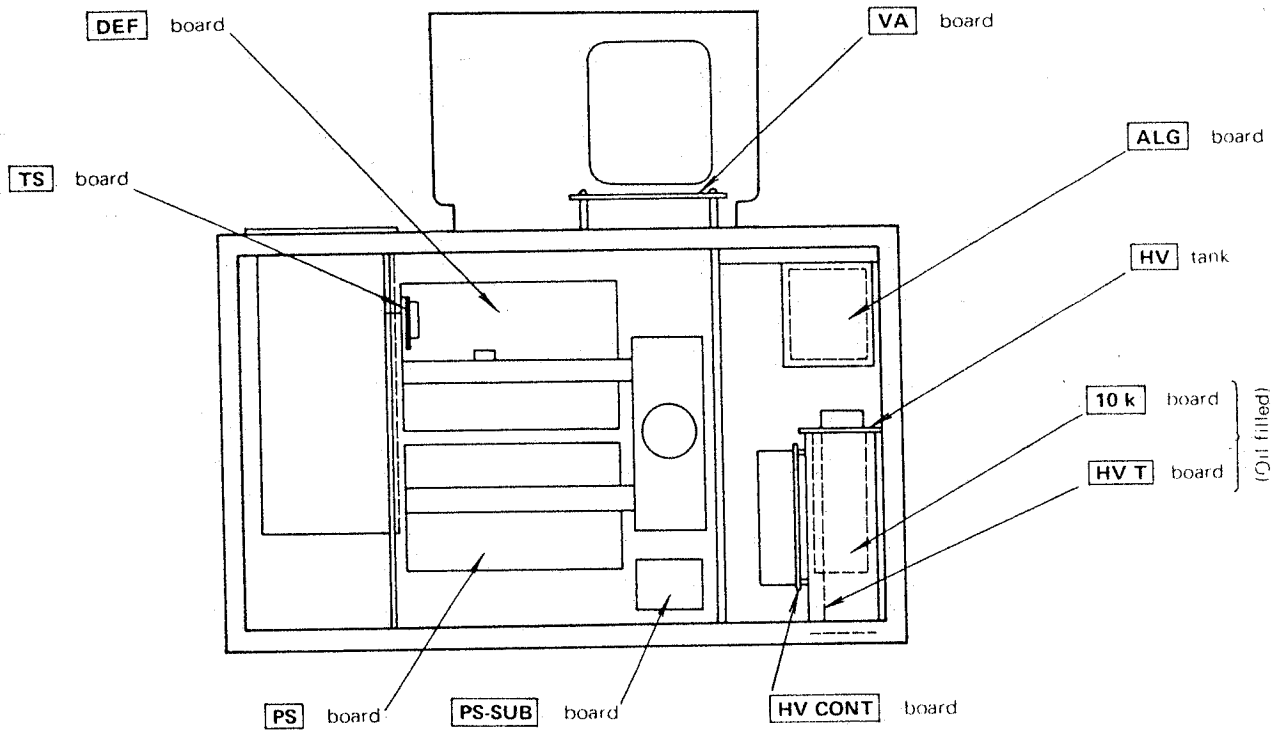

Fig. 2-3 Wiring between Display Unit and Column

234 Arrangement and Dismounting Procedure of Display Unit Components



Appearance of Display Unit



Rear View

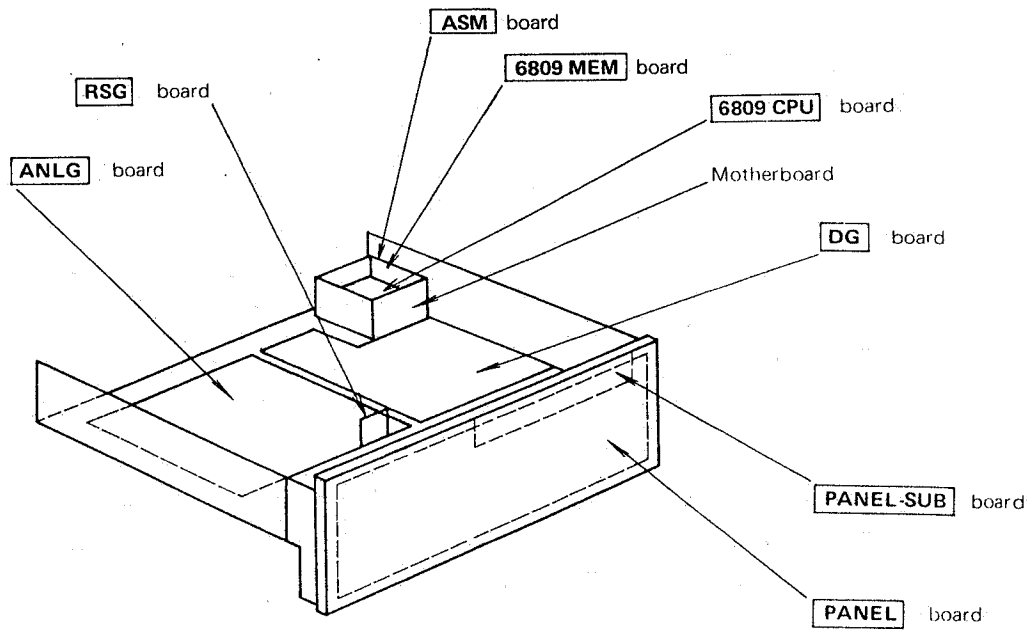

Operation Unit

How to Dismount External Components

1. Operation unit

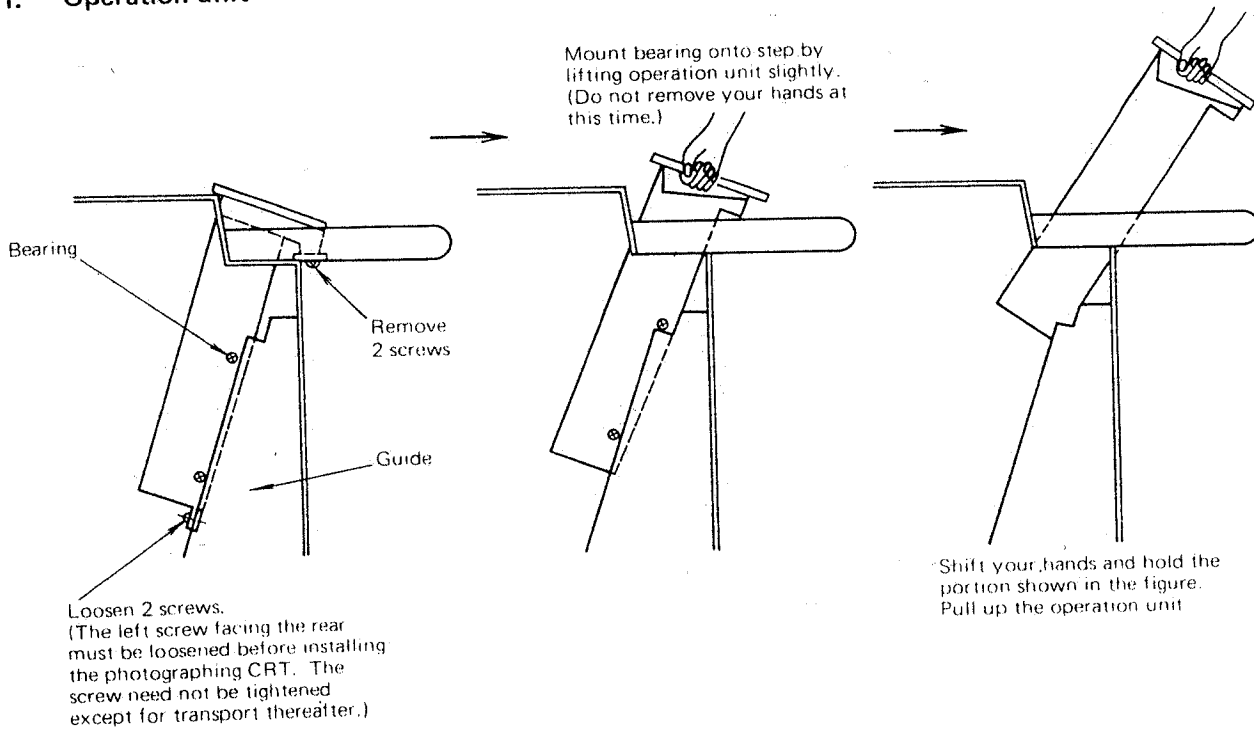

2. ALG unit

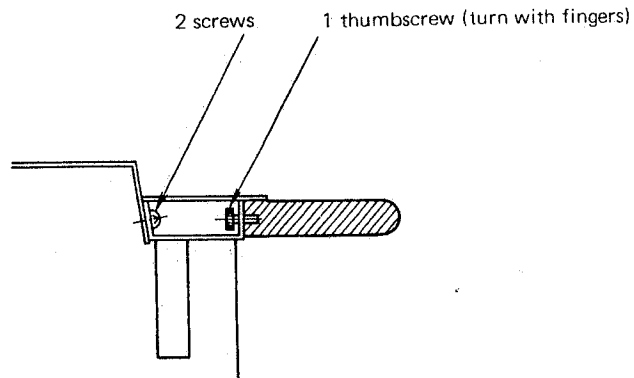

3. HV tank

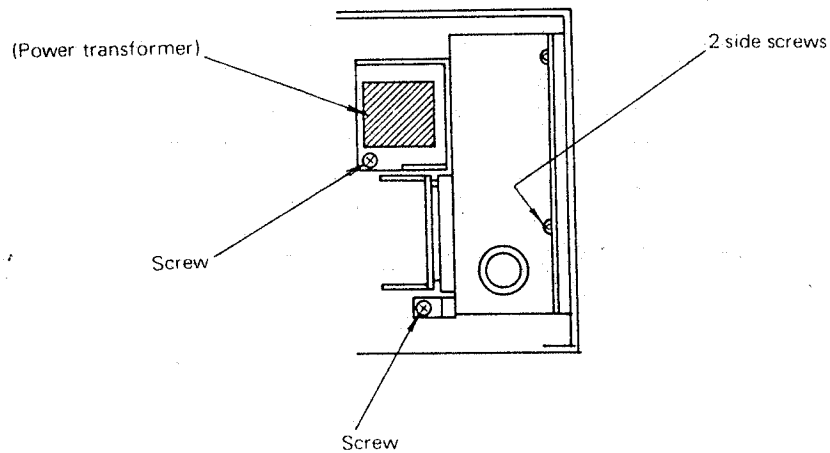

2-3-5 Check after Assembling

On completion of entire assembling, recheck all the procedures that have been taken for assembling. Make sure that no error has been made in any assembling procedure. Particularly, check that the column is not in contact with the column side cover and no cords are pinched in between the covers.

2-4 Installation of Model S-5704 Mode/Dual Mag. Control Unit

1. Cord connection, jumper connector, and switch setting

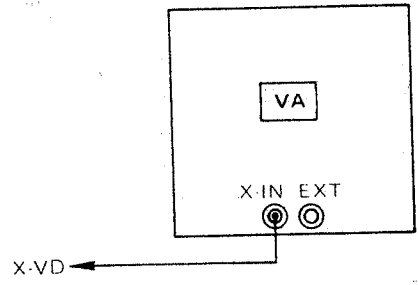
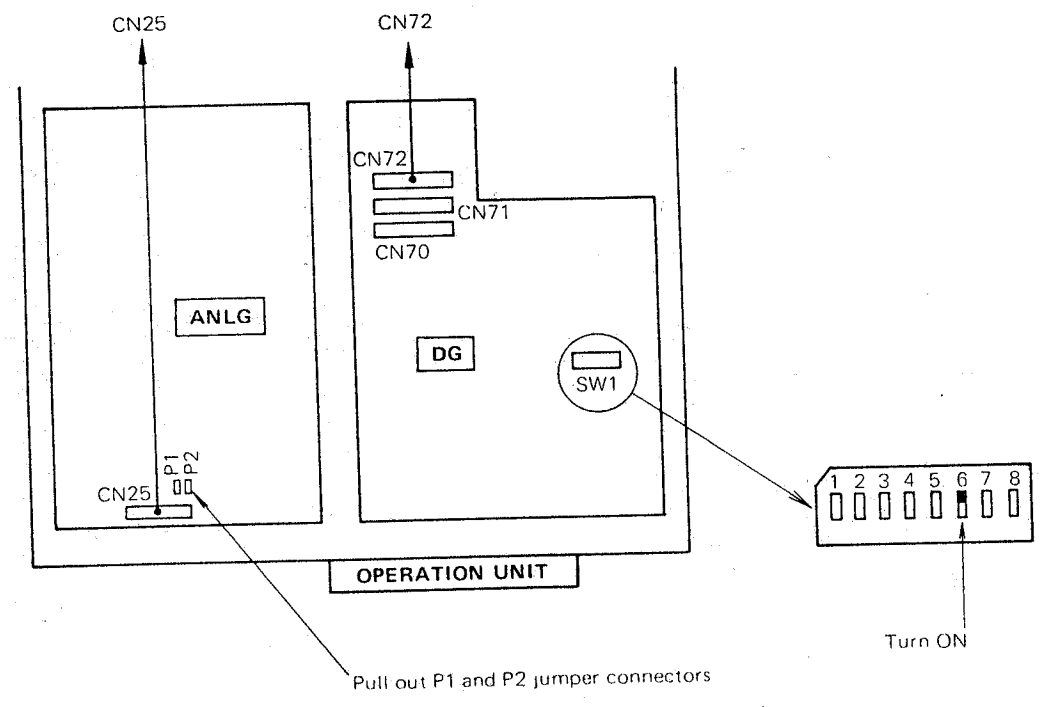

2. Connection of S-5704 and EDX units

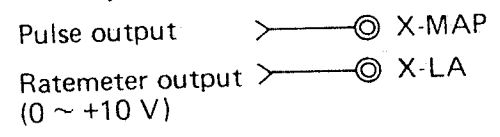

Note: The ratemeter range setting should be from 0 to +10 V. '±' select jumper is provided in S5704 unit.

CONTENTS

3. TECHNICAL INFORMATION	3-1
3-1 Structure of Main Unit	3-1
3-1-1 Electron Gun	3-1
3-1-2 Condenser Lens	3-1
3-1-3 Objective Lens	3-1
3-1-4 Objective Lens Movable Aperture	3-1
3-1-5 Secondary Electron Detector	3-1
3-1-6 Lower Bias Terminal	3-1
3-1-7 Specimen Goniometer Stage	3-1
3-2 Evacuation System	3-12
3-2-1 Specifications	3-12
3-2-2 Structure	3-13
3-3 Display Unit	3-15
3-3-1 Composition	3-15
3-3-2 Composition and Function of ANLG Circuit Board Blocks	3-16
3-3-3 Composition and Function of DG Circuit Board Blocks	3-24
3-3-4 Description of Data Display Circuit	3-27

3. TECHNICAL INFORMATION

3-1 Structure of Main Unit

Fig. 3-1 shows a sectional view of the main unit.

- (1) The objective lens movable aperture is located above the deflection coils.
- (2) The objective lens is cooled with liquid.
(Except for S-2500C)
- (3) The secondary electron detector is provided with top and bottom scintillators.
(Bottom scintillator only in S-2500C)
- (4) The oil diffusion pump and evacuation valve compose an integral unit.

3-1-1 Electron Gun (See Fig. 3-2)

3-1-2 Condenser Lens (See Figs. 3-3 and 3-4)

3-1-3 Objective Lens (See Figs. 3-5 and 3-6)

The objective lens employs a circulatory liquid-cooling system because of its high excitation current of about 3 A.

The coolant is circulated by the cooling unit separately installed. (For maintenance of the cooling unit, refer to "4-6 Maintenance of Cooling Unit" in the instruction manual.)

When using the upper secondary electron detector, a bias voltage of +30 to +100 V can be applied to the objective lens fixed aperture (a pipe structure) in order to enhance secondary electron yield. (Except for S-2500C)

3-1-4 Objective Lens Movable Aperture (See Fig. 3-7)

3-1-5 Secondary Electron Detector (See Figs. 3-8 and 3-9)

The light emitted from 2 scintillators provided above and below the objective lens is led to a single photomultiplier via the light guide. The detectors can be selected with POST HV switch equipped behind the blank panel. (Except for S-2500C)

3-1-6 Lower Bias Terminal (See Figs. 3-8 and 3-9)

To increase yield at a low accelerating voltage, a bias of approx. 150 V is applied to the collector electrode.

3-1-7 Specimen Goniometer Stage (See Figs. 3-10, 3-11 and 3-12)

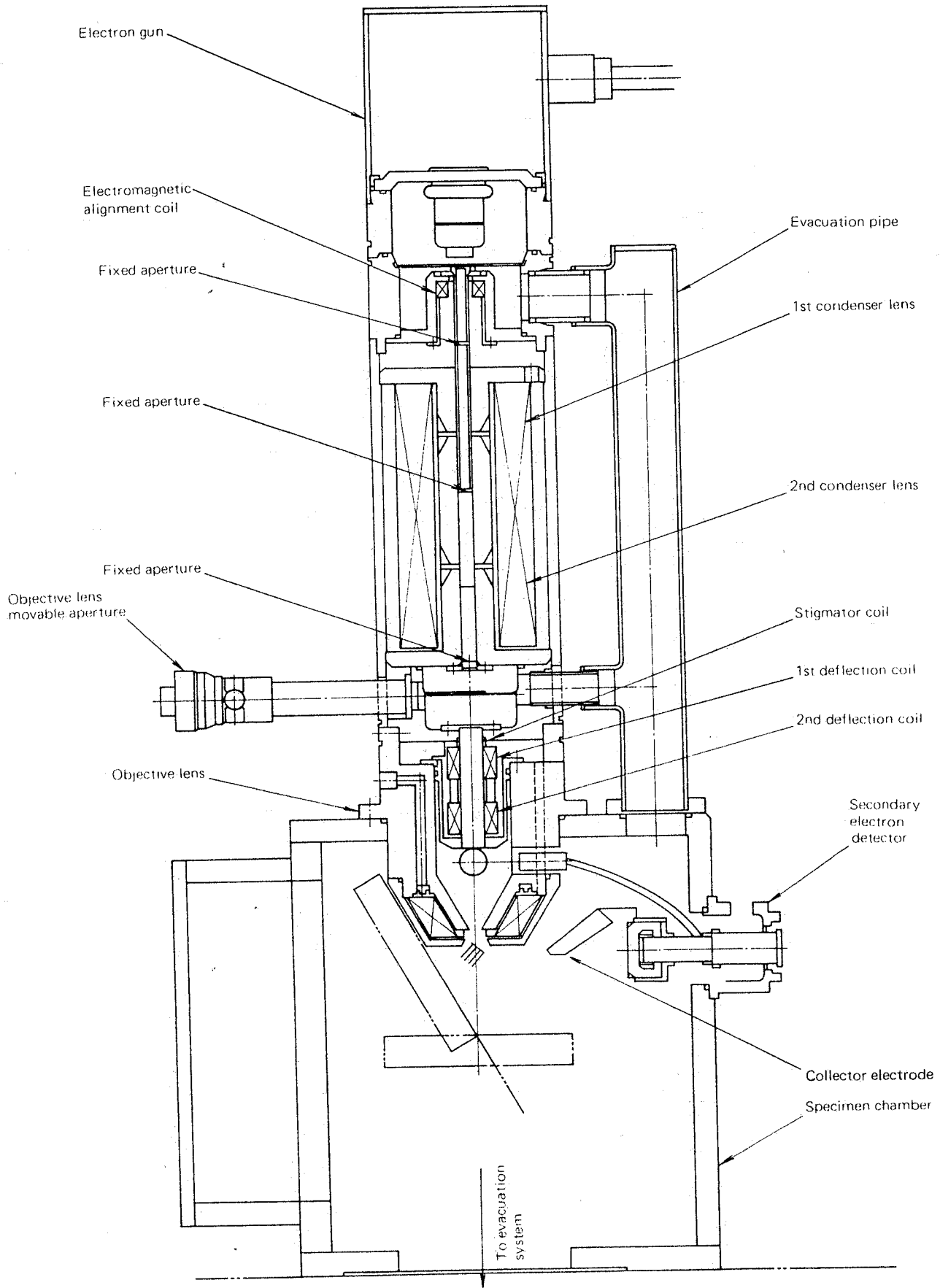

Fig. 3-1 Sectional View of Main Unit

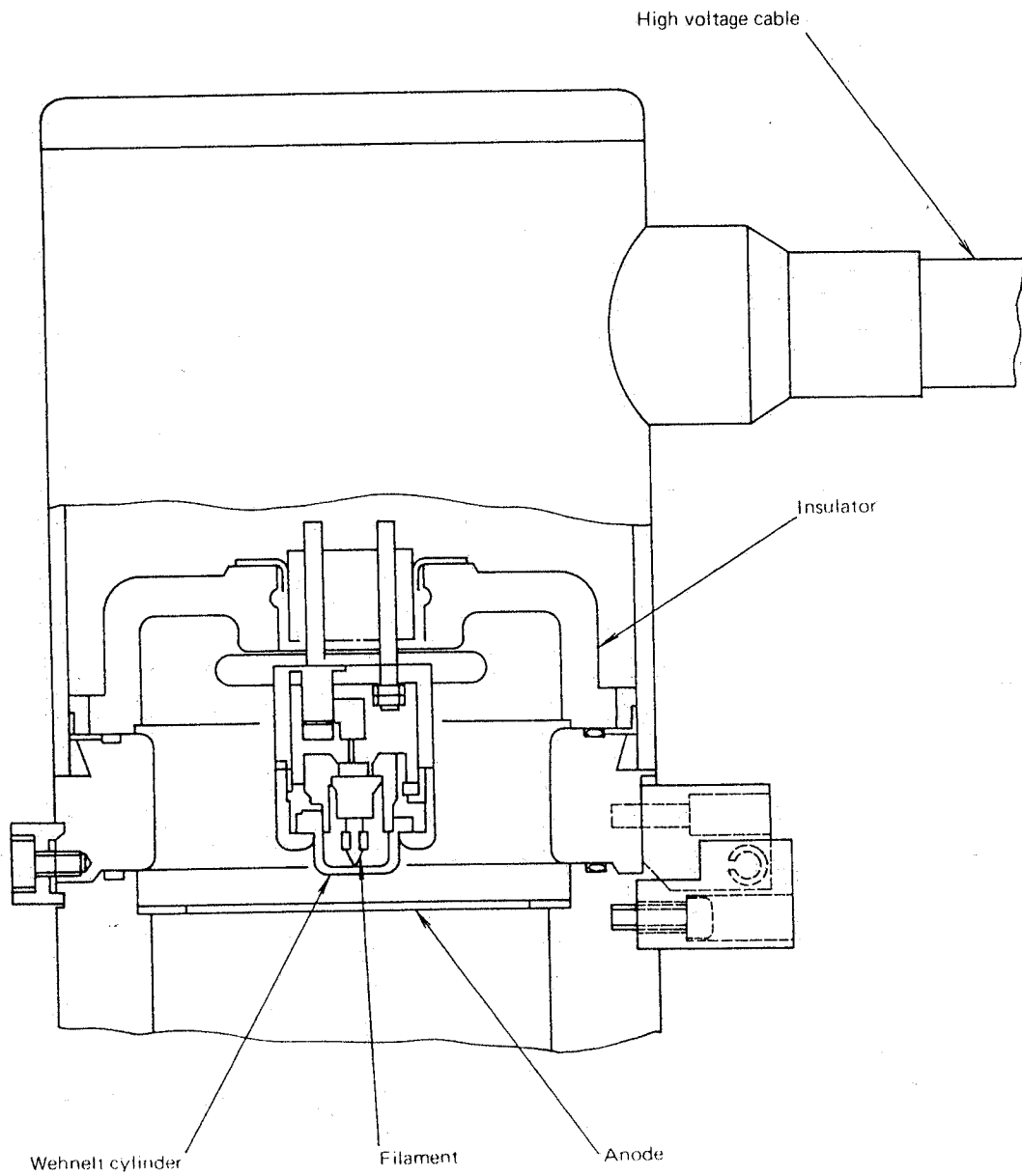

Fig. 3-2 Sectional View of Electron Gun

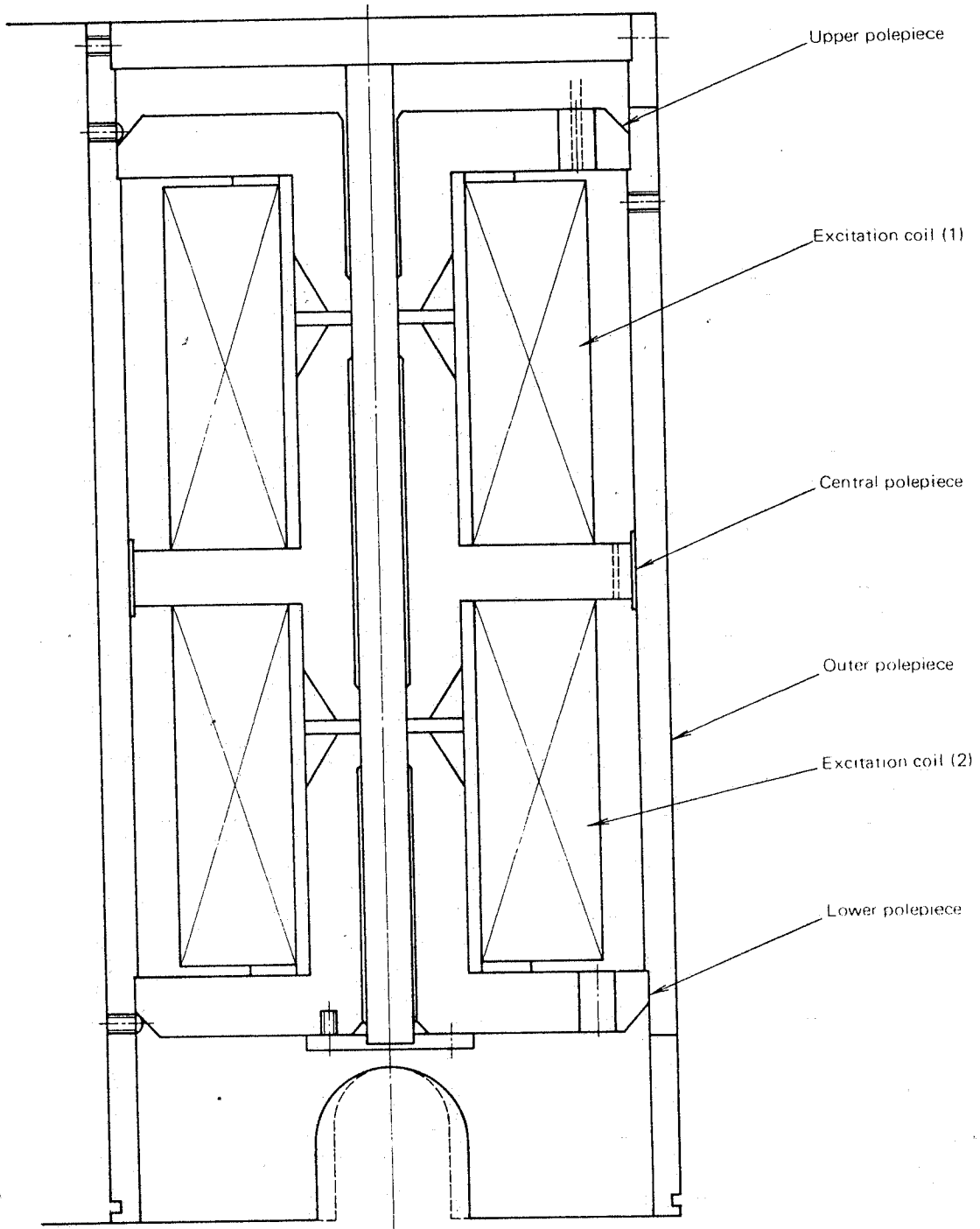

Fig. 3-3 Sectional View of Condenser Lens (S-2500)

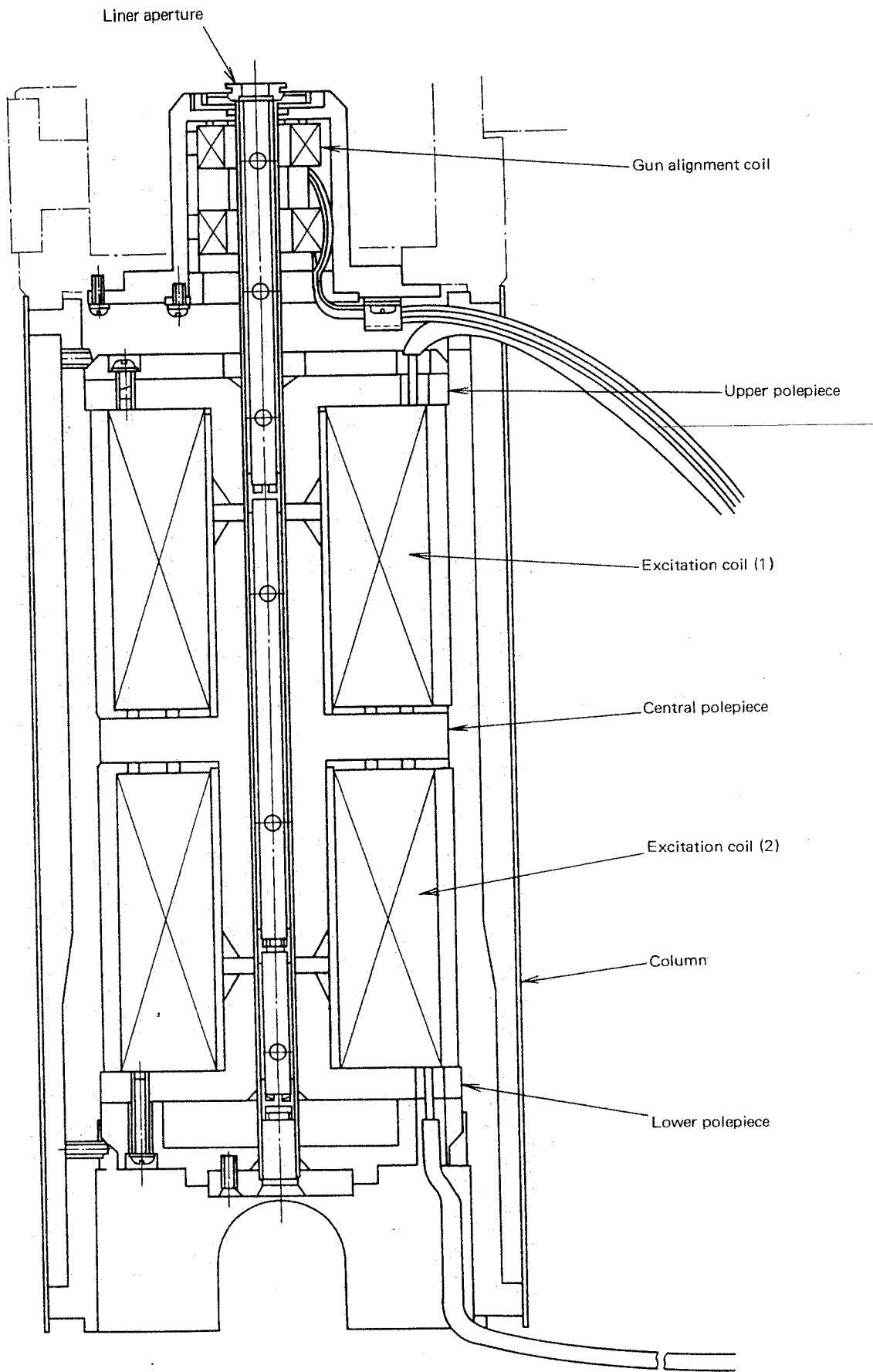

Fig. 3-4 Sectional View of Condenser Lens (S-2500C)

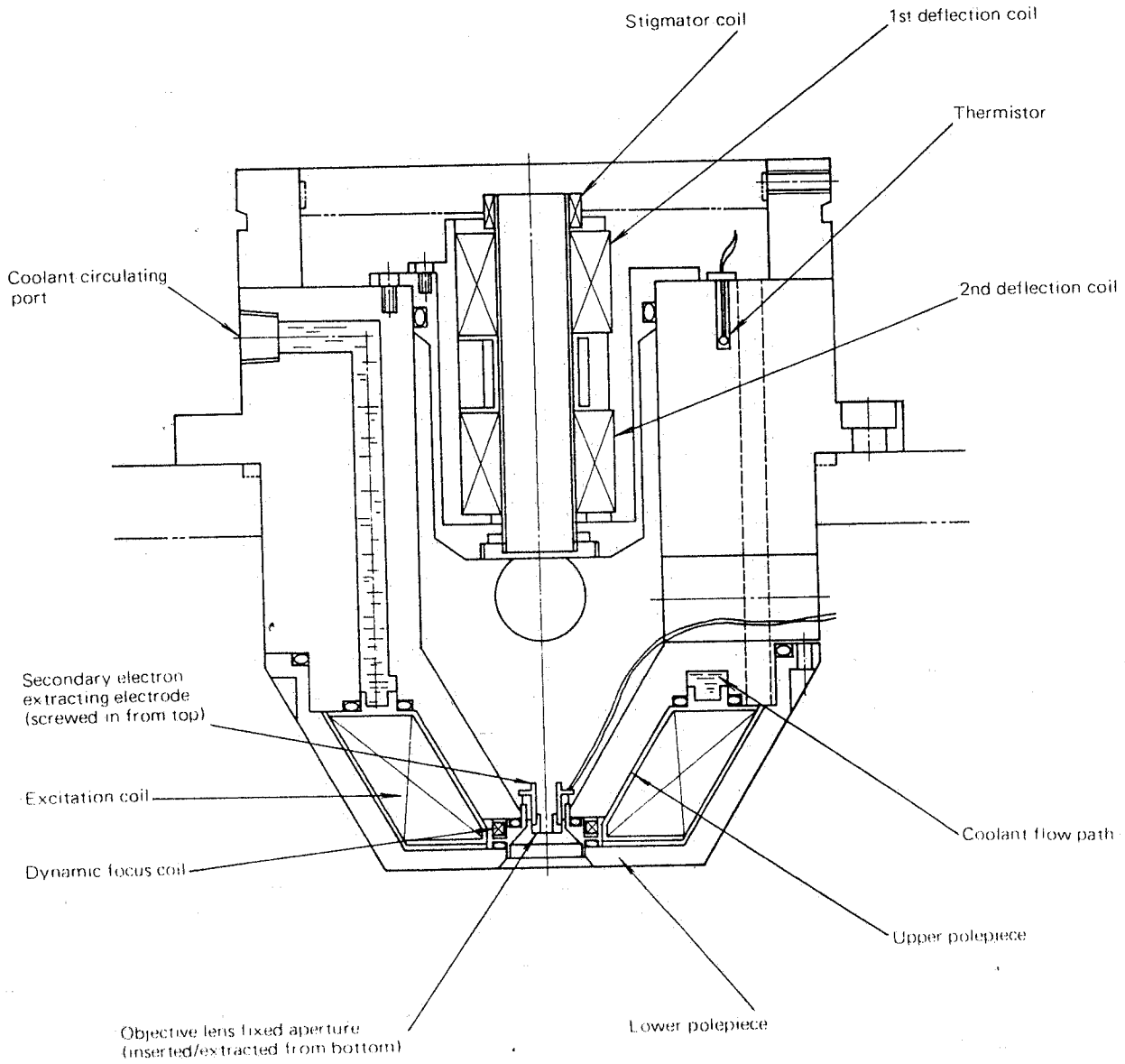

Fig. 3-5 Sectional View of Objective Lens (S-2500)

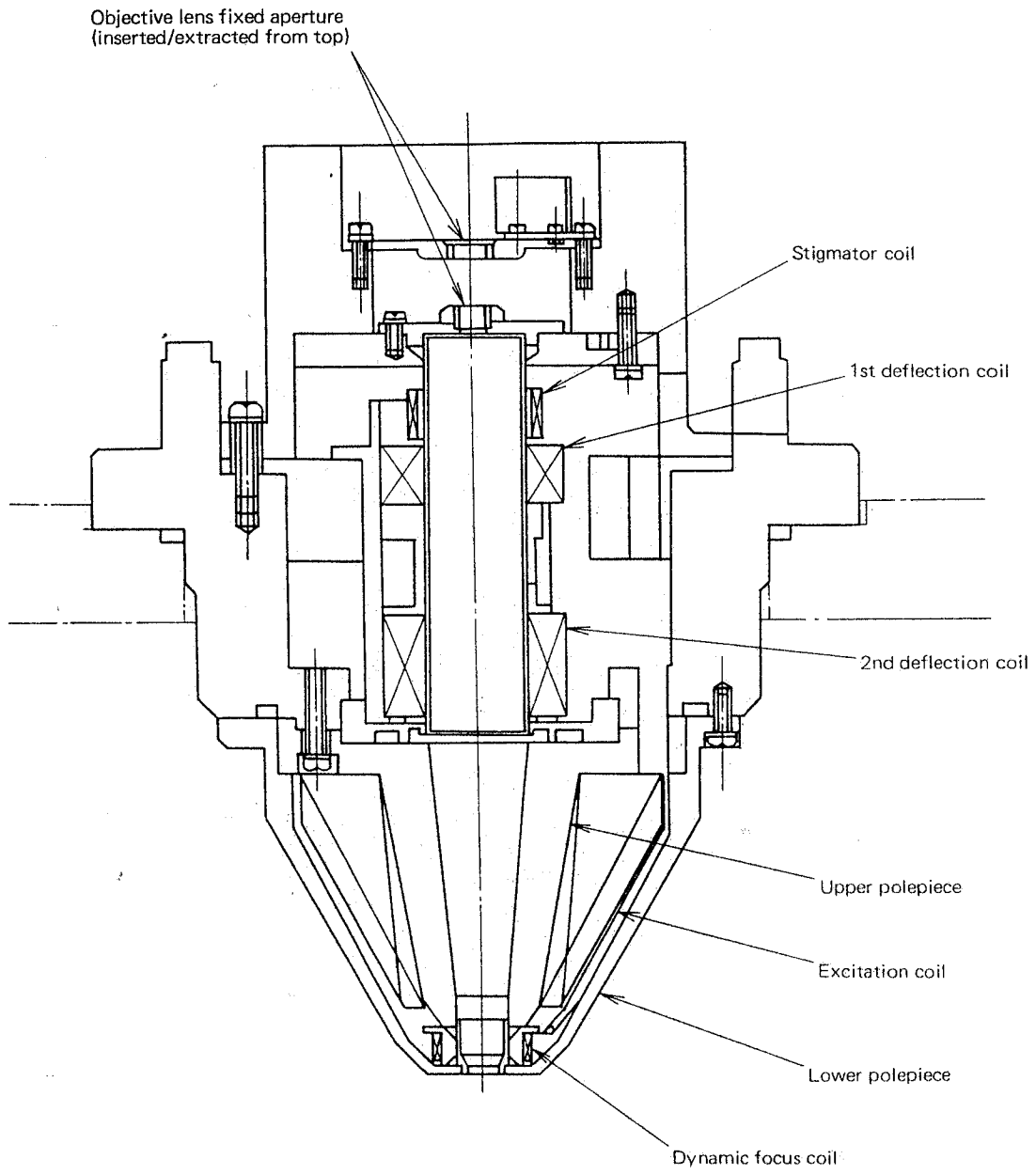

Fig. 3-6 Sectional View of Objective Lens (S-2500C)

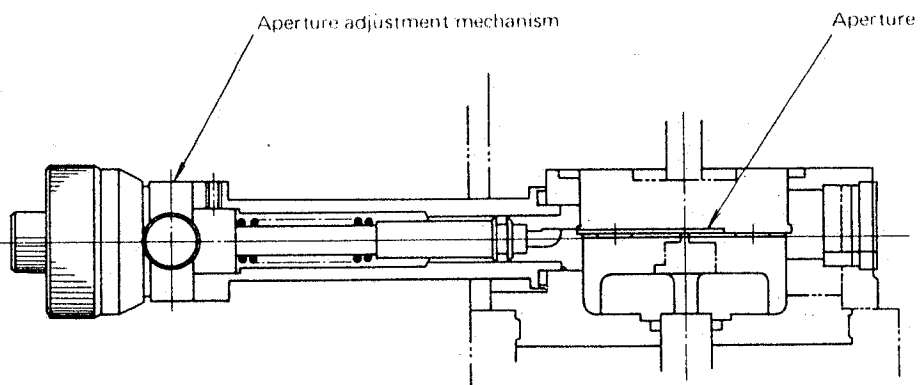

Fig. 3-7 Sectional View of Objective Lens Movable Aperture Assembly

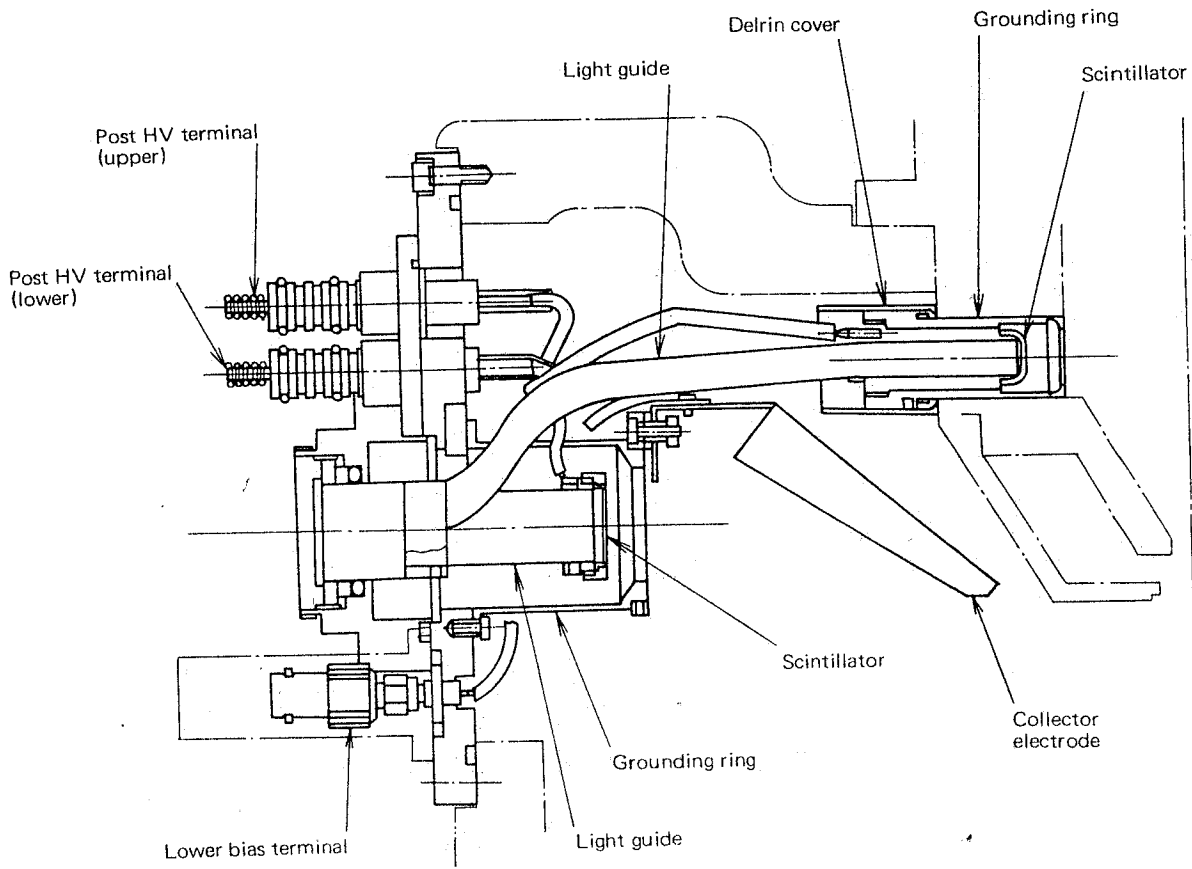

Fig. 3-8 Sectional View of Secondary Electron Detector (S-2500)

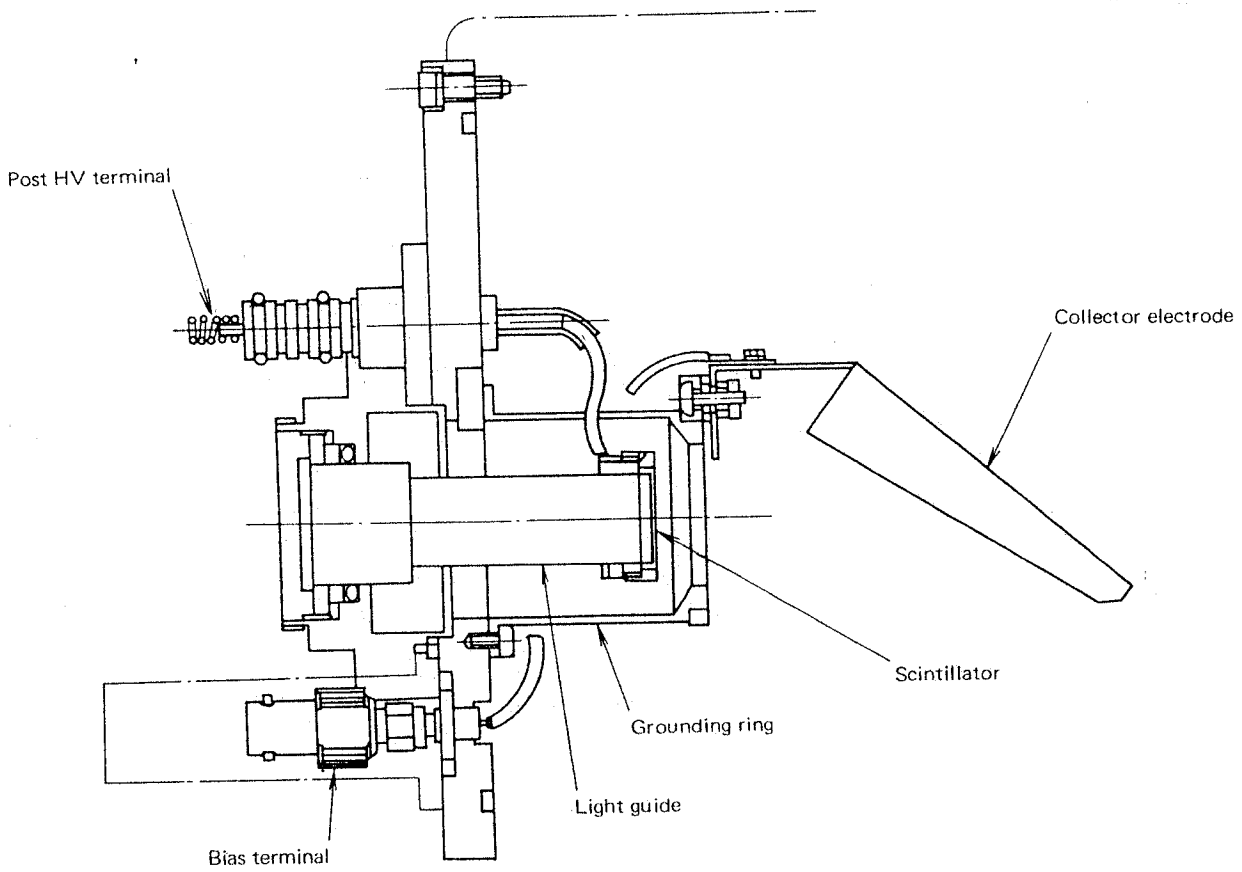

Fig. 3-9 Sectional View of Secondary Electron Detector (S-2500C)

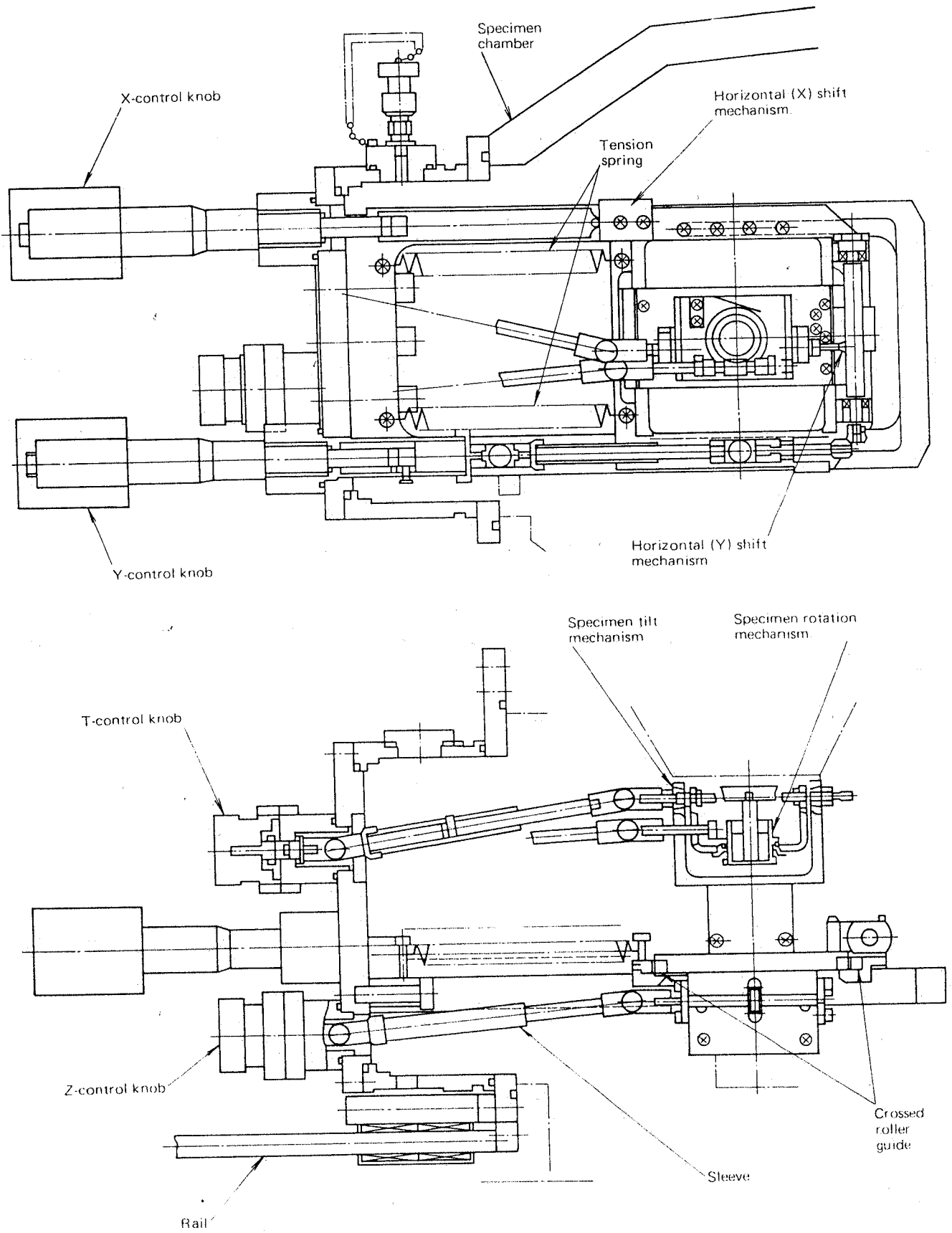

Fig. 3-10 Sectional View of Standard Specimen Goniometer Stage

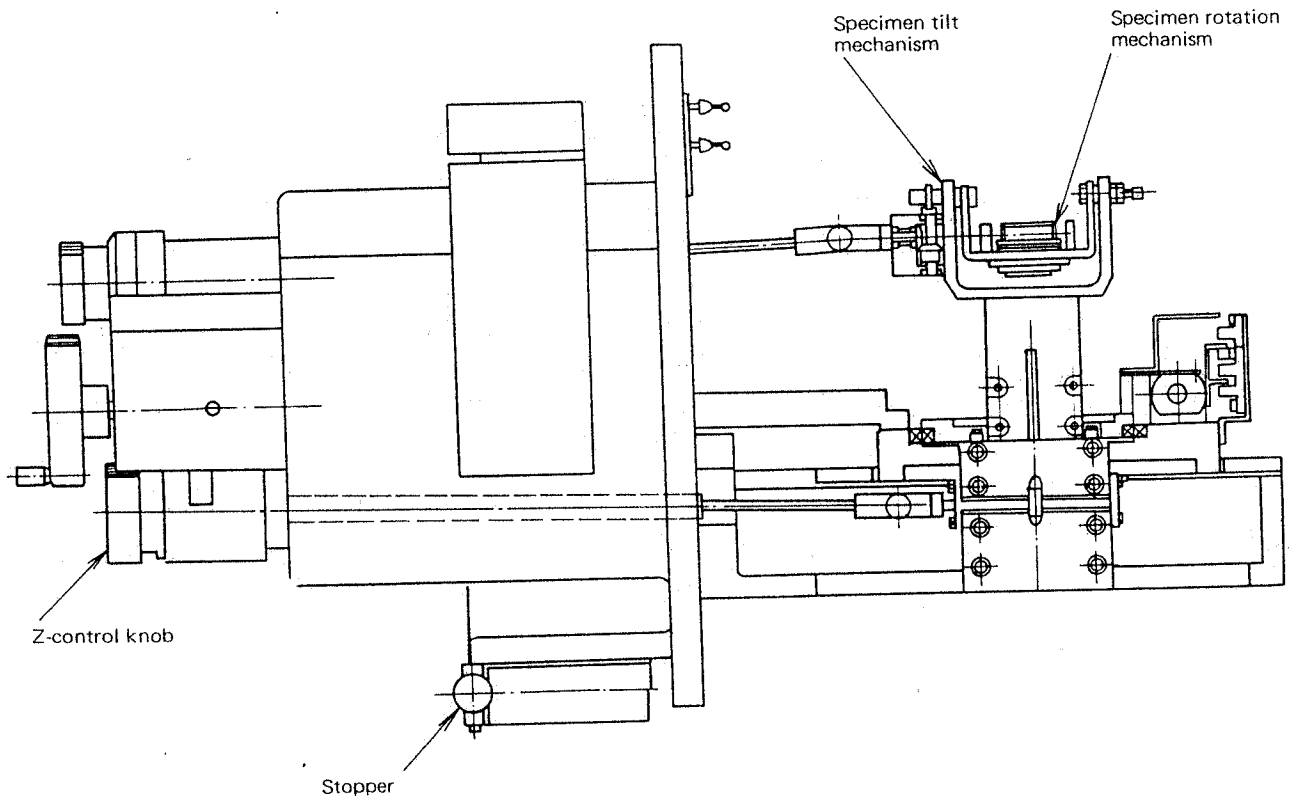
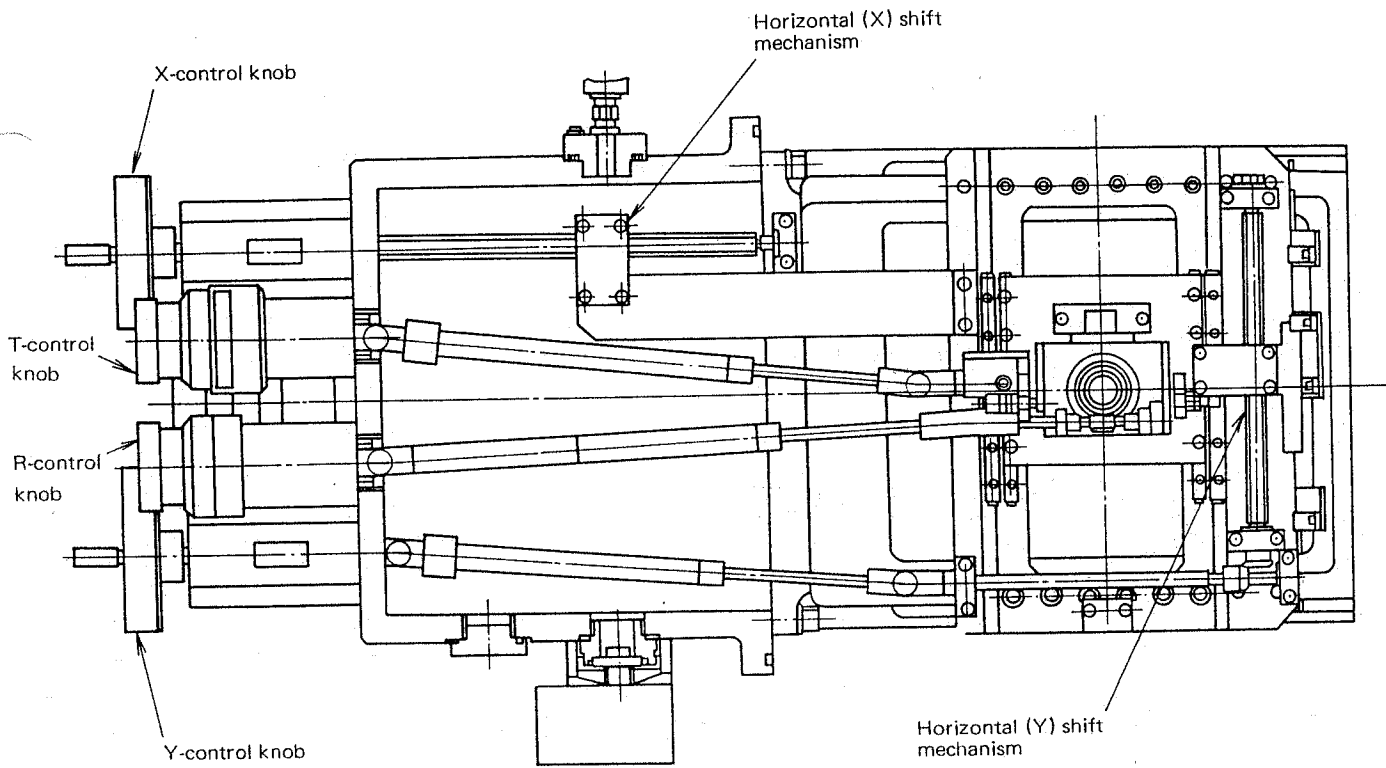

Fig. 3-11 Sectional View of Large-Sized Specimen Goniometer Stage A

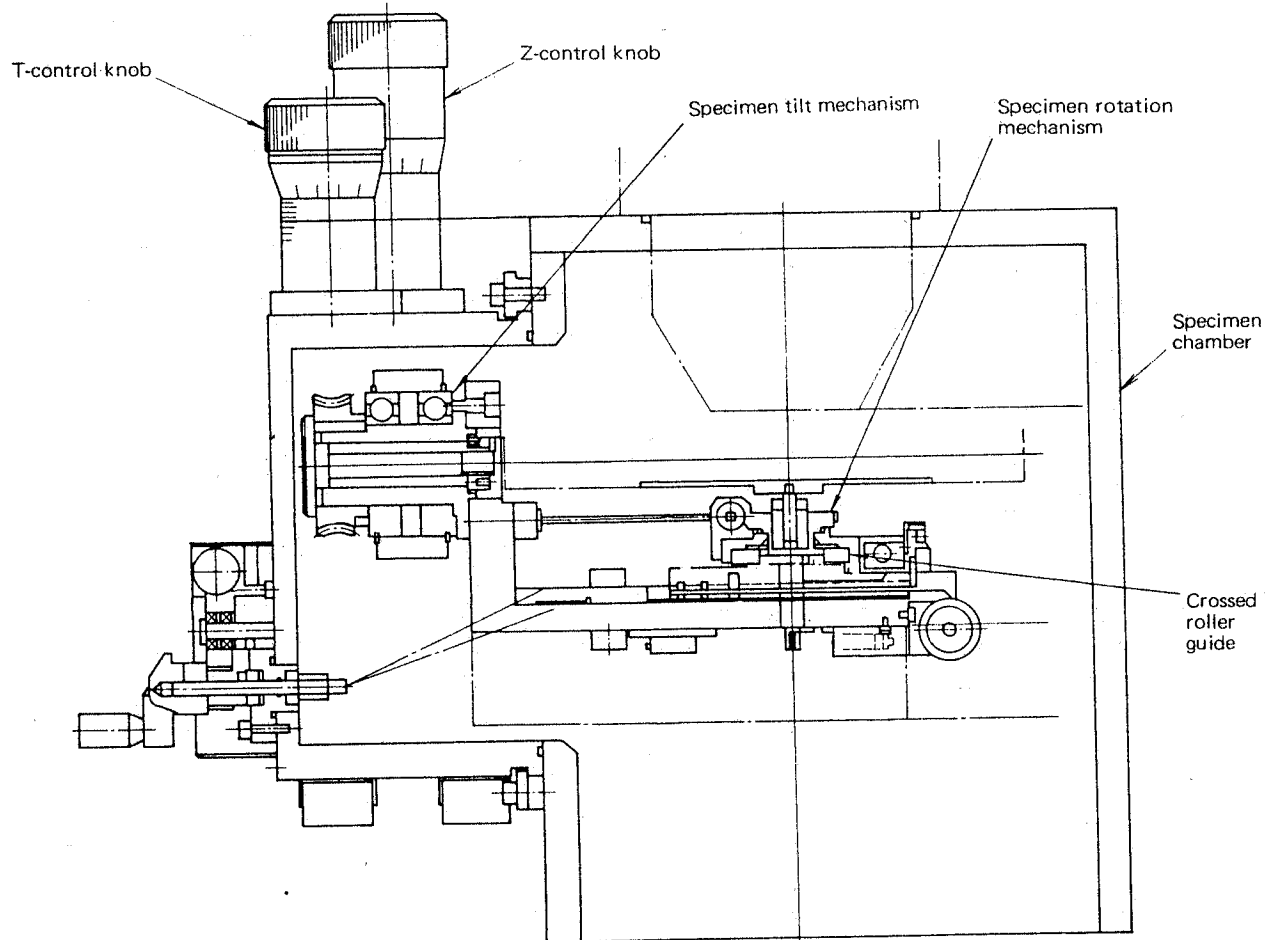
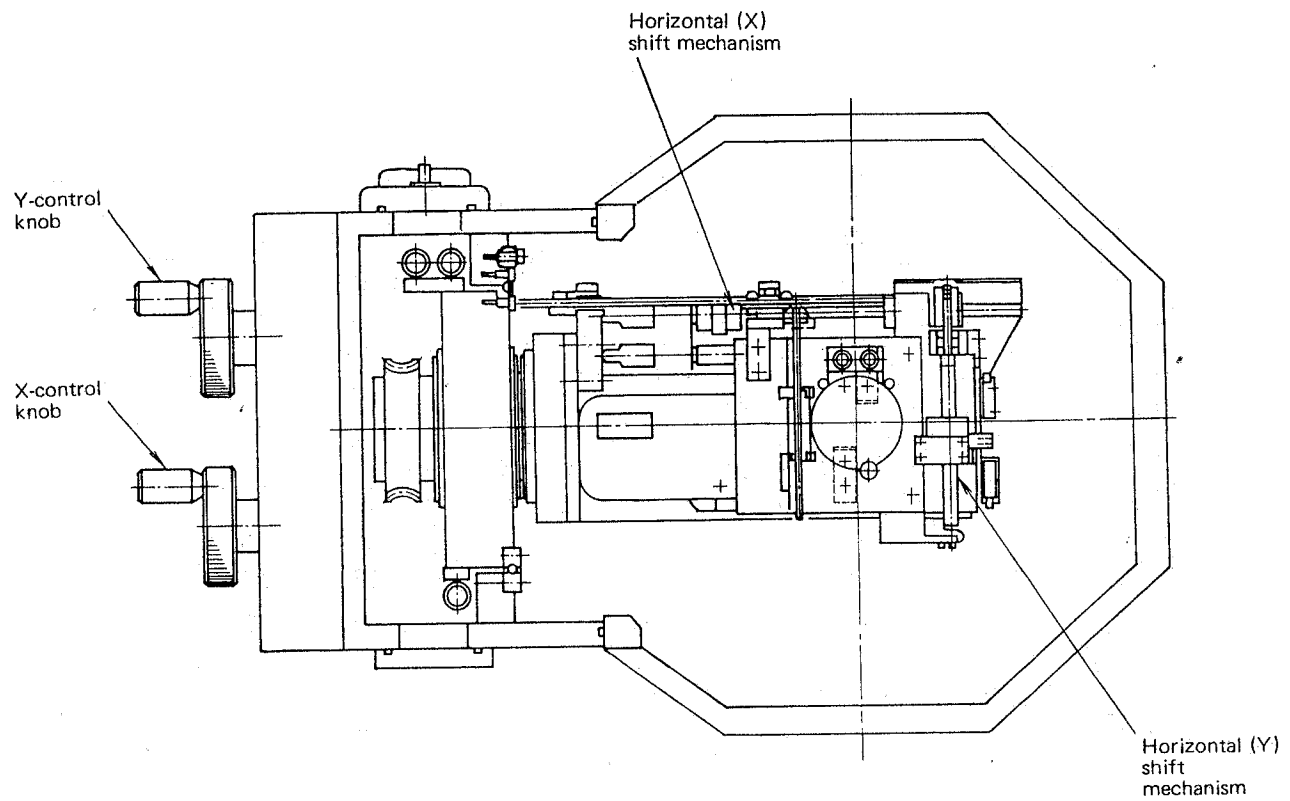

Fig. 3-12 Sectional View of Large-Sized Specimen Goniometer Stage B

3-2 Evacuation System

3-2-1 Specifications

(1) System model DSS-421H

(2) Composition

① Oil diffusion pump DPF-4ZS

Power supply : 100 V, 500 W
Pumping speed : 570 L/s
Ultimate pressure : 2×10^{-7} Torr
Critical backpressure : 2×10^{-1} Torr
Oil used and its volume : Lion S, 150 cc
Water flowrate : 1.5 L/min

② Main valve CAV-4

Switching : Driven by 4-way electromagnetic valve
Drive air pressure : 3 to 5 kg/cm²

③ 3-way valve 3AW-25

Switching : Driven by two 3-way electromagnetic valves
Drive air pressure : 3 to 5 kg/cm²

3-2-2 Evacuation System Structure

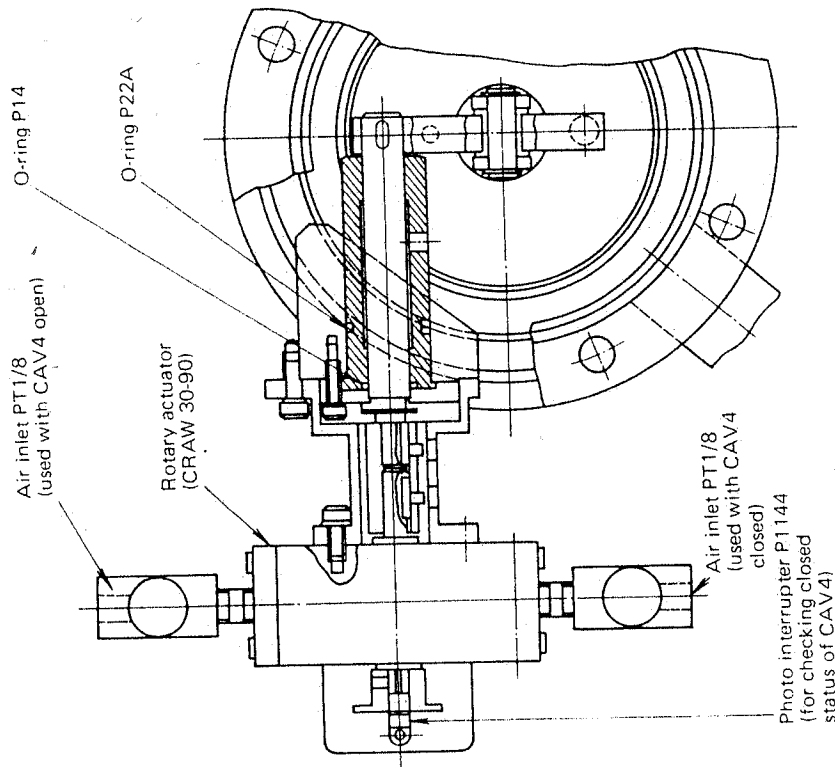
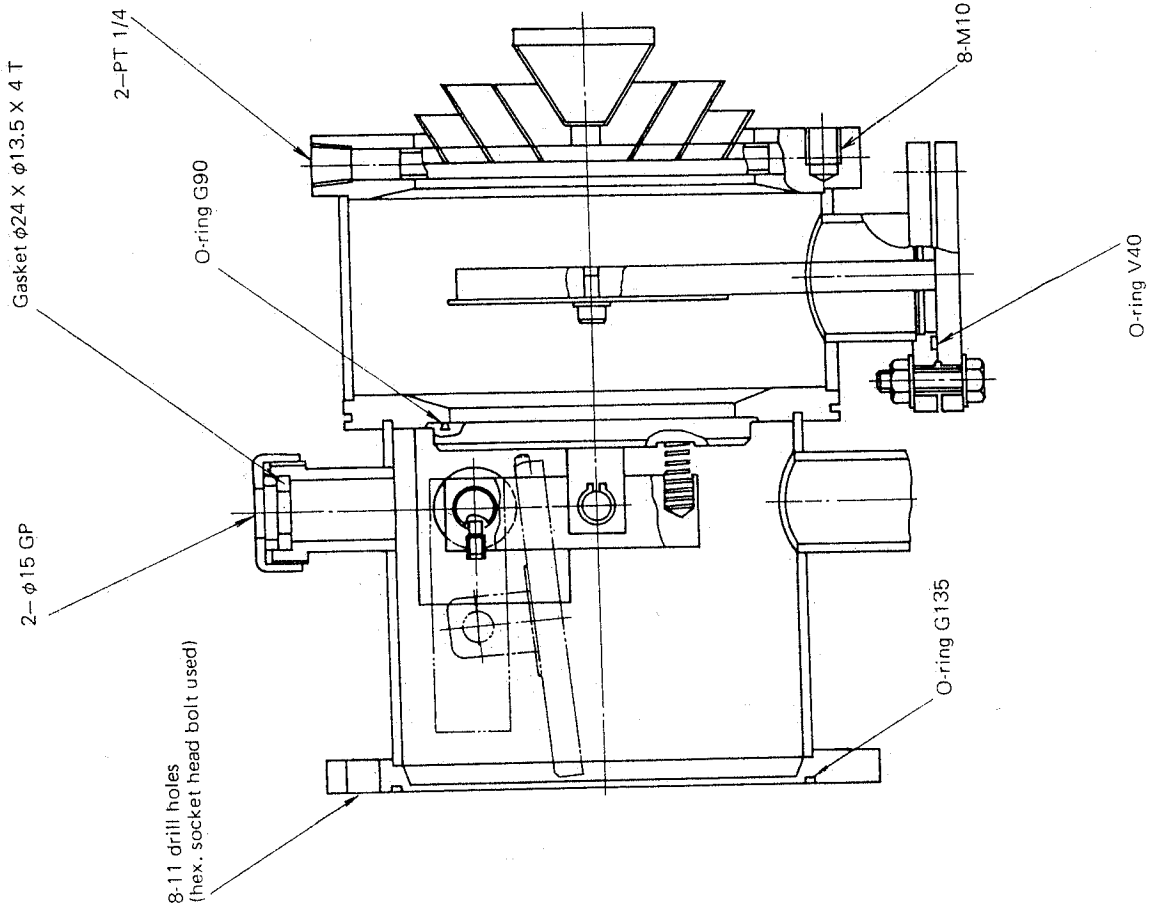

Fig. 3-13 Structure of Main Valve

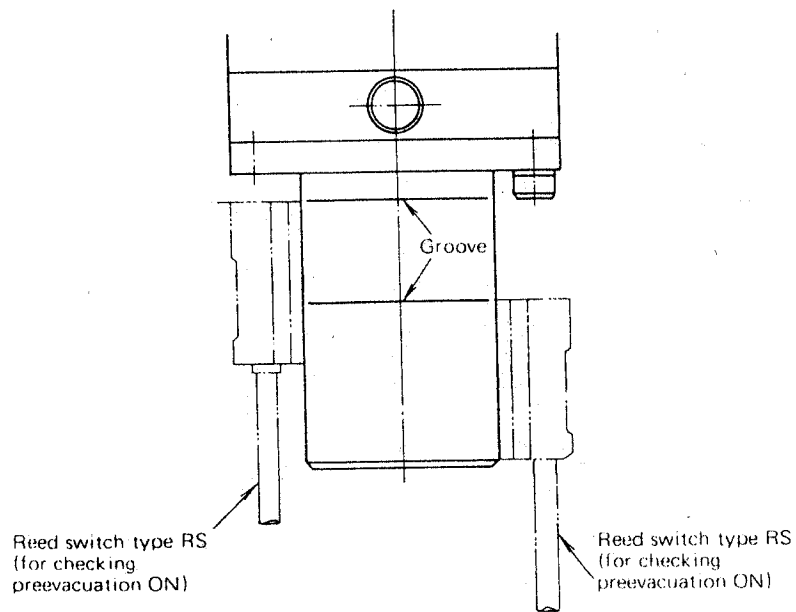
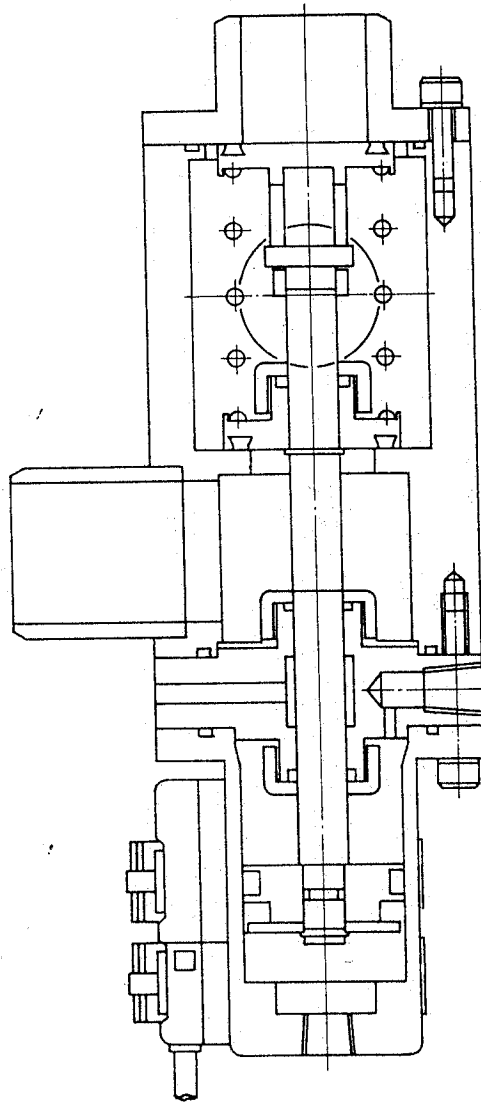

Fig. 3-14 Structure of 3-Way Valve for Evacuation with Oil Rotary Pump

3-3 Display Unit

3-3-1 Composition

Fig. 3-15 shows the arrangement of the circuit boards which compose the display unit. For arrangement of each component, refer to 2-3-4.

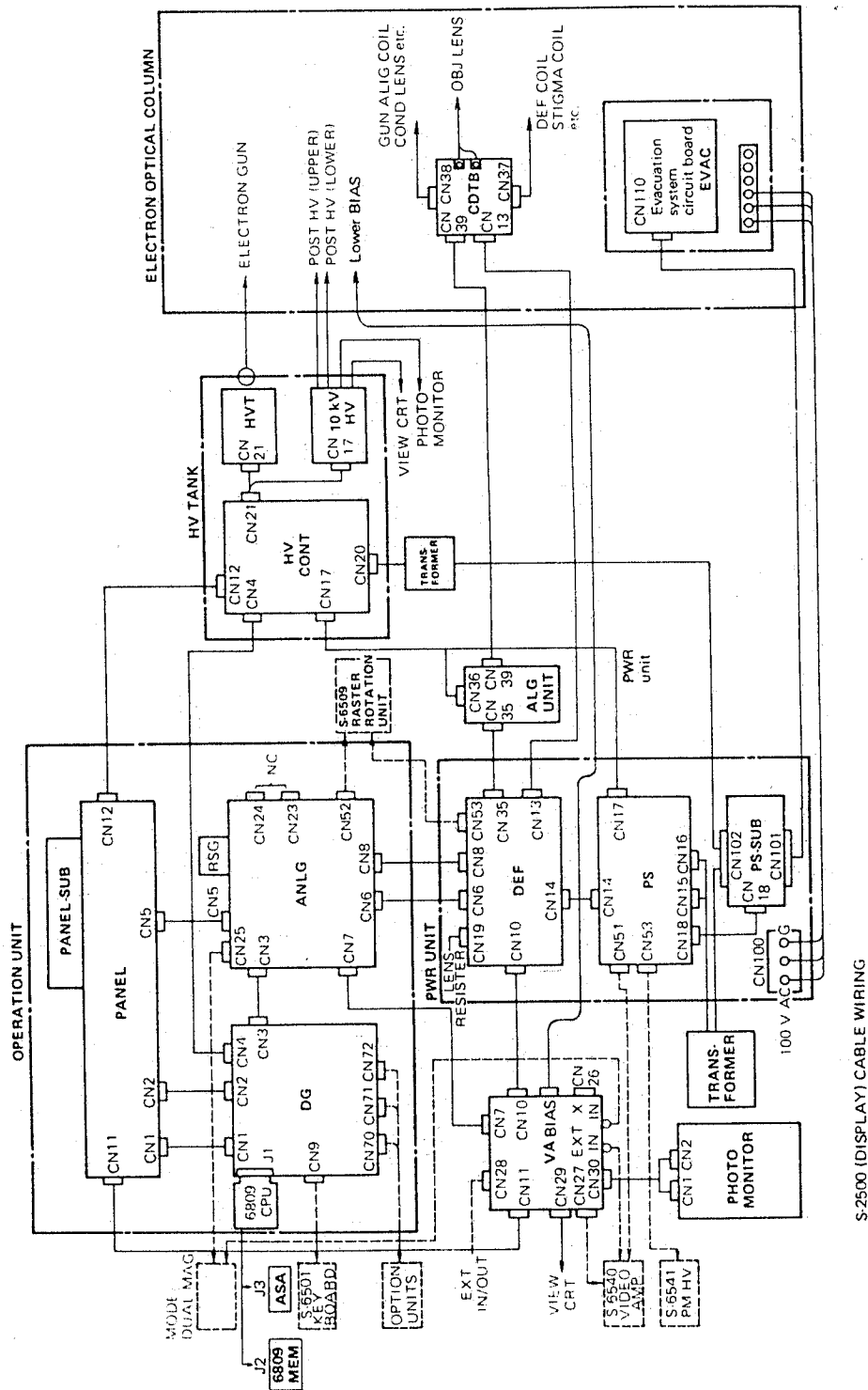

Fig. 3-15 Composition of Display Unit

S-2500 (DISPLAY) CABLE WIRING

3-3-2 Composition and Function of ANLG Circuit Board Blocks

(1) Function of each block

- a) SG block
Generation of scan signal (sawtooth wave) and scan signal for auto focus (X_C , Y_C), and generation of blanking signal
- b) MODE CONT block
- Distribution of scan signal to CRT and column deflection circuits, and adjustment of amplitude
 - Magnification changeover and its adjustment
 - Function for splitting screen
 - Generation of cross mark (stigmator monitor)
- c) VDO CONT block
- Condition setting and control of video amp (VA circuit board)
 - ABC (Automatic Brightness/Contrast Control) circuit
 - Focus detection circuit for auto focus
- d) LENS CONT block
- Reference voltage circuits for objective/condenser lenses, stigmator, gun alignment, image shift, etc. (current amplifier provided with **DEF** circuit board)

(2) Function of each circuit

No.	Circuit	Function	Ref. item No.
1	Reference voltage circuit	<ul style="list-style-type: none"> • Generates voltage for determining amplitude of output voltage of X and Y sweep generators. • 10 V (full span) and 3.38 V (for reduced area mode) selectable for each of X and Y. 	4-3-5
2	X sweep generator circuit	<ul style="list-style-type: none"> • Generates sawtooth wave voltage for X (horizontal) scan. • Scan speed is determined by current flowing through \ominus input terminal of IC C20. Slow speed of 20 ms or more is determined by data setting of IC B20 to D/A converter. • Amplitude is determined by reference voltage described above. • Either free run or externally triggered generation (synchronization with power supply) is selected according to the status of R-S flipflop consisting of IC A16. 	4-3-5

No.	Circuit	Function	Ref. item No.
3	Y sweep generator circuit	<ul style="list-style-type: none"> Generates stepwise sawtooth-wave voltage by integrating flyback pulse which is generated by the above X sweep generator for each scan. Amplitude is determined by reference voltage described above. No. of scan lines (steps) is changed (within a range of 250 to 2,000) by both altering input current to integrator in 2 steps (1 : 2) and changing over gain of subsequent amplifier (IC C16) with switch (IC C14). Either free run or external trigger is selected according to setting of flipflop consisting of IC B16. 	4-3-5 Fig. 4-10
4	Oscillator for rapid scan	<ul style="list-style-type: none"> Oscillates pulse (at intervals of 100 μs) for driving CRT X deflection circuit (switching system) and column deflection X sawtooth wave generator circuit only when scan speed RAPID is selected. 	Fig. 4-11 Fig. 4-13
5	Sync signal generator circuit	<ul style="list-style-type: none"> Generates pulse of power frequency from AC voltage (2 V). The pulse is used as external trigger signal for X and Y sweep generators (in REDUCE AREA) in order to effect power-frequency-synchronized scan. 	Fig. 4-9 Fig. 4-10
6	Blanking signal circuit	<ul style="list-style-type: none"> Generates pulse for blanking CRT during flyback of X and Y sawtooth wave signals. Independent X-BL and Y-BL signals, and composite $\overline{\text{BLK}}$ signal (sum of X and Y signals) available. 	Fig. 4-9 Fig. 4-10
7	X_C and Y_C oscillators	<ul style="list-style-type: none"> Generates sine wave (X_C) and integrates it to generate wave (Y_C) having phase difference of 90°. These waves are generated only in auto focus mode. 	4-3-5
8	RSG circuit board	<ul style="list-style-type: none"> Generates (X) sawtooth wave for column deflection in rapid scan mode. Forms sawtooth wave by resetting Miller integrator circuit periodically with drive pulse in "4" above. Rapid scan uses CRT deflection circuit differing from the one for slow scan. So, column deflection circuit differs between rapid and slow scans. 	4-3-2 Fig. 4-8
9	X mode selector circuit	<ul style="list-style-type: none"> Changes over signal toward CRT and column X deflection circuits (switch IC D20). Makes changeover with rapid scan signal in "8" above for column deflection (switch IC E20). 	4-3-5 Fig. 4-9

No.	Circuit	Function	Ref. item No.
10	Y mode selector circuit	<ul style="list-style-type: none"> • Changes over signal toward CRT and column Y deflection circuits (switch IC D19). • Makes changeover with or addition of video signal (for waveform display mode) (switch IC D17). 	4-3-5 Fig. 4-10
11	Split screen circuit	<ul style="list-style-type: none"> • Effects column deflection twice for each CRT scan by shifting Y waveform for column deflection toward (+) side in the earlier half and (-) side in the latter half. • Changeover signal is generated by Y-split comparator in "16" below. 	4-3-5
12	CRT X deflection signal adjuster circuit	<ul style="list-style-type: none"> • Adjusts amplitude and level of CRT X deflection signal. • Capable of independent width and location adjustments for each of viewing and photographing CRTs in both image observation and photographing modes. 	4-4
13	CRT Y deflection signal adjuster circuit	<ul style="list-style-type: none"> • Adjusts amplitude and level of CRT Y deflection signal. • Capable of independent width and location adjustments for each of viewing and photographing CRTs in both image observation and photographing modes. 	4-4
14	Magnification circuit	<ul style="list-style-type: none"> • Changes magnification by altering amplitude of scan wave within range of 1 to 1/10 with D/A converter. (Digit is selected by changing over detection and shunt resistances of current amplifier (in DEF circuit board)). • Adjustment circuit for calibrating magnification is provided after D/A converter. Two adjustment circuits are provided for adjusting the upper and lower working distance ranges (with reference to 0 mm) independent of each other. 	4-5
15	Cross mark generator circuit	<ul style="list-style-type: none"> • Generates pulse for displaying cross mark signal in stigmator monitor mode. In this mode, switch IC E16 is turned off, and pulse is generated by comparator IC D16 and D14 according to comparison of reference voltage $0 \pm \Delta V$ and X/Y scan signals. • In position set mode with mode/dual mag control unit, IC E16 is turned on and MANUAL position voltage is input as reference voltage (mark shiftable). 	4-3-5

No.	Circuit	Function	Ref. item No.
16	Y-split comparator	<ul style="list-style-type: none"> Compares Y scan signal and 0 V, and generates at a mid point of Y scan the changeover signals SP1/SP2 (for changeover of split screen circuit in "11" above and video signal) and blanking signal SPBL. 	4-3-5
17	Data latch and data buffer	<ul style="list-style-type: none"> Receives and stores each signal for controlling SG and MODE CONT blocks transmitted from CPU. CPU is capable of controlling each section through writing data here. Signal is always moving before data latch, while it is fixed after latch until different data are written. 	4-13
18	FVDO signal circuit	<ul style="list-style-type: none"> Generates voltage for determining CRT grid voltage in modes such as WAVEFORM and SPOT requiring fixed CRT brightness. Voltage is determined by data written from CPU onto D/A converter (IC F2). 	4-3-5
19	Contrast loop circuit	<ul style="list-style-type: none"> In ABC (Automatic Brightness/Contrast Control) circuit, forms contrast control loop for changing photomultiplier power supply through detection of maximum peak value with respect to average video amplifier output. Maximum peak is detected by D310 and C306. From detected value, average value is deducted via R354, and then contrast reference voltage (VR301-R320) is subtracted. Output voltage of IC F6 charges integrator (IC F4L-C307) via R326 when switch IC F5 closes momentarily at the end of Y scan. When IC F6 output becomes 0 V at the end of Y scan, therefore, integrator is not charged, so balance is attained. Integrator output becomes reference voltage of photomultiplier power supply via photocoupler F4U. 	
20	Brightness loop circuit	<ul style="list-style-type: none"> Detects average output of video amplifier and changes bias voltage of preamplifier so that average output becomes 0 V. Forms brightness control loop. Video signal is integrated in integrator circuit of IC F7-C301 during Y scan (thereby becoming average value). If the output is not 0 V, integrator (IC F3-C308) is charged via R375 when switch IC F5 closes momentarily at the end of Y scan. Output of integrator IC F3 becomes bias voltage of SE preamplifier, which changes average video signal level. When IC F7 output becomes 0 V at the end of Y scan, balance is attained. 	

No.	Circuit	Function	Ref. item No.
21	Timing circuit	<ul style="list-style-type: none"> At the end of Y scan, first (1) momentarily closes switch (⑩ ~ ⑪ , ⑦ ~ ⑥ of IC F5) and transmits detected peak and average levels to integrator (IC F4L, F3), and then (2) resets peak hold circuit (D310, C306) and average level integrator circuit (IC F7, C301). 	4-3-5
22	Settling detection circuit	<ul style="list-style-type: none"> Detects peak level signal (IC F6 output) and average level signal (IC F7 ① pin output) with a pair of window comparators (IC F10U) each having a window width of $0 V \pm \Delta V$, and generates interrupt signal ($\overline{INT3}$) if both signals are within $0 V \pm \Delta V$ at the end of Y scan. Upon reception of $\overline{INT3}$, CPU terminates ABC operation. If the above $\overline{INT3}$ is not generated in 5 seconds, CPU automatically terminates ABC operation at a determined time point. 	4-3-5
23	Focus signal amplifier	<ul style="list-style-type: none"> Obtains absolute video signal level by differentiation and integrates it during a single scan for monitoring auto focus. IC F11 is amplifier (its gain is selected by switch IC F10L). Its output is differentiated by C305 and IC E11 (pre-stage), rectified (into absolute value) by D301, D302 and IC E11 (post-stage), and integrated by IC E10 (pre-stage) and C401 during each scan. IC B7 controls timing. According to \overline{CST} signal generated for each scan, switch (IC F10L ③ ~ ② pins) is momentarily closed, and integrated value at that time is held in C304. At the same time, interrupt signal ($\overline{INT1}$) is generated in order to input completion of each scan into CPU. Then, integrator (IC E10, post-stage) is reset. 	4-3-5
24	A/D converter circuit	<ul style="list-style-type: none"> Analog output voltage of D/A converter (IC C9, D10L) is changed sequentially according to CPU and compared by comparator (IC D10U) with the focus signal level held in capacitor C304 as described in "23" above. Thus, data in IC C9 are input to CPU in digital format. 	4-3-5
25	Signal selector circuit	<ul style="list-style-type: none"> Either of two SIGNAL SELECT switches is selected, according to which of SE, EXT and X-RAY signals is selected in \overline{VA} circuit board. IC B8 is a (2 → 1) demultiplexer. Selective input S (\overline{LHLF}) is usually at level "1" and outputs SIGNAL SELECT switch 1 status (Y_1, Y_2). In split screen mode, \overline{LHLF} signal becomes level "0" only when Y scan is within the latter half (lower half of CRT) and outputs switch 2 status, thereby forming image selected by switch 2 onto CRT. 	

No.	Circuit	Function	Ref. item No.
26	Video amp control register	<ul style="list-style-type: none"> Records data (filter, signal polarity, gamma control, etc.) for setting conditions of video amp. 	
27	Data latch and buffer	<ul style="list-style-type: none"> Same as in "17" above except that VDO CONT block signal is handled. 	4-13
28	Reference voltage circuit	<ul style="list-style-type: none"> Generates reference voltage for lens, stigmator and other circuits. Generates voltage of $10\sqrt{HV/30}$ (both positive and negative, $+V_{Ref}$ and $-V_{Ref}$) from output (+10 V) of high accuracy reference voltage IC (IC C10-AD581) by transmitting data proportional to square rooted accelerating voltage from CPU to D/A converter. 	4-13 Fig. 4-14
29	Objective lens control circuit	<ul style="list-style-type: none"> Reference voltage circuit for objective lens power supply. Composes 16-bit D/A converter by connecting upper 8 bits of 12-bit DAC (IC C7) and 8-bit DAC (IC C6). Controllable range of objective lens current is divisible with reference to working distance (WD) 0 mm. In IC D7, adjustments of output voltage in $WD \leq 0$ and $WD \geq 0$ ranges are made independent of each other with variable range fine control trimmer changed over by switch (IC E6). 	4-13 4-7-1 Fig. 4-14
30	Condenser lens control circuit	<ul style="list-style-type: none"> Generates reference voltage for condenser lens power supply circuit by dividing/attenuating $-V_{Ref}$ generated in "28" above with rotary switch (2CON) and VR (ICON). 	4-7-2
31 32	Stigmator (X, Y) Control circuits	<ul style="list-style-type: none"> Generate input voltage to stigmator power supply circuit by adding potentiometer output, AUTO STIGMA unit output and X (Y) scan signals (added only in stigmator monitor mode). (Note that stigmator is not interlocked with magnification.) 	4-8 Fig. 4-15
33	Scan signal attenuator	<ul style="list-style-type: none"> Controls amplitude of X and Y scan signals to be added to stigmator (in stigmator monitor mode) and gun alignment (in filament image mode). Amplitude is determined by data transmitted from CPU to D/A converter ICs C5 and C4 (varies with accelerating voltage, magnification, etc.). 	4-3-5 Fig. 4-15
34 35	Gun alignment control circuits	<ul style="list-style-type: none"> Only add scan signal since gun alignment currents (TILT X/Y and HORIZ X/Y) are generated by ALG unit (IC C3 and C2 not provided). 	4-3-5

(Continued)

No.	Circuit	Function	Ref. item No.
36	Dynamic focus control circuit	<ul style="list-style-type: none">• Supplies power to dynamic focus coil placed in objective lens gap and is used in auto focus mode.• Amplitude and polarity of excitation current are CPU-controlled according to DAC (IC C1) and switch (IC E2) respectively.	4-3-5
37 38	Image shift control circuits	<ul style="list-style-type: none">• Provide image shift function. Besides, add (1) AFC alignment signal (A_X and A_Y in circuit diagram) for correcting image shift occurring when changing dynamic focus current in "36" above, and (2) stigmator alignment signal (S_{XX}, S_{XY}, S_{YX}, S_{YY}) for correcting image shift occurring when manipulating stigmator control knobs.	4-3-5
39	Data latch and buffer	<ul style="list-style-type: none">• Same as in "17" and "27" except use for LENS CONT block.• Data latch circuit unused since almost all D/A converters incorporate latch.	4-13

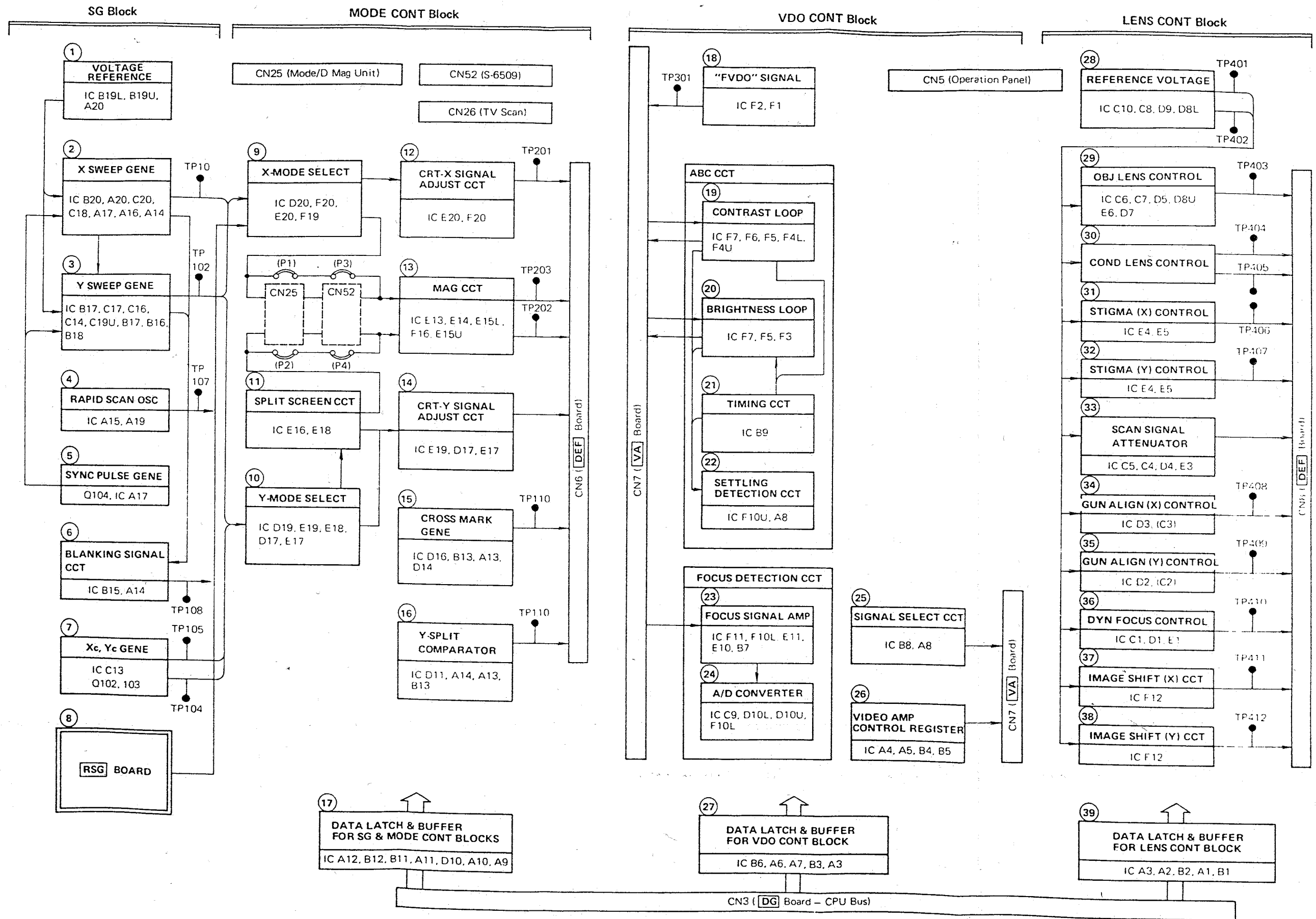

Fig. 3-16 Block Diagram of ANLG Circuit Board

3-3-3 Composition and Function of DG Circuit Board Blocks

(1) Block composition

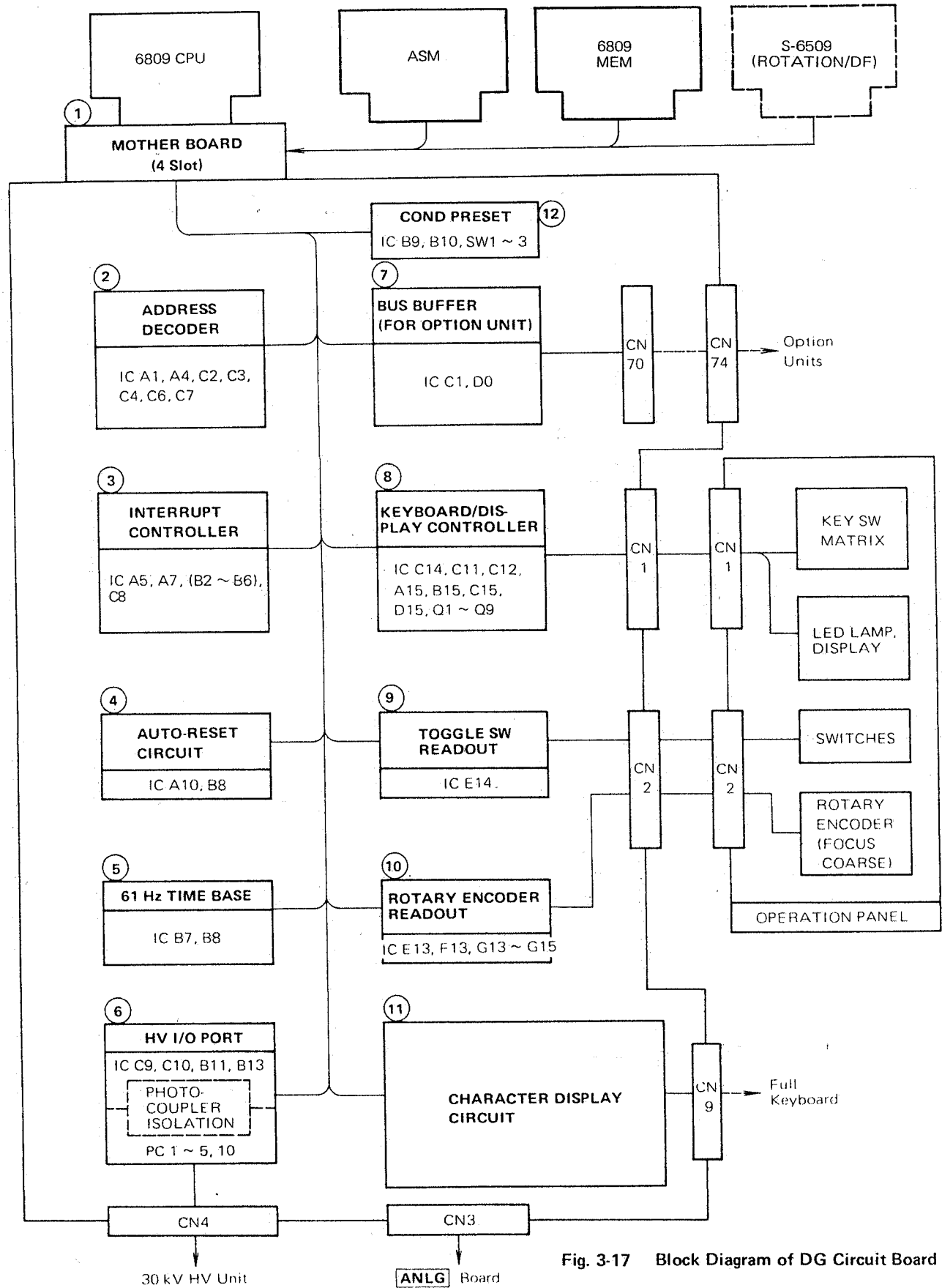

Fig. 3-17 Block Diagram of DG Circuit Board

(2) Function of each circuit component

No.	Circuit	Function	Ref. item No.
1	Mother board	<ul style="list-style-type: none"> • Connects CPU and other circuit boards. • Among 4 slots, lower 3 slots are used for 6809 CPU, memory circuit board and stigmator circuit board. • Upper 1 slots are used for I/O circuit board. 	
2	I/O address decoding section	<ul style="list-style-type: none"> • Decodes upper 13 bits of 16-bit address and assigns them to each I/O section. • These bits are called "Device Number", and the following 16 numbers are used. DVN0 ~ DVN7 DVOP0 ~ DVOP7 • Each I/O section can use 8 addresses in a combination of one device-number bit and the lower 3 address bits. 	I/O address map 4-13
3	Interrupt processing function	<ul style="list-style-type: none"> • Instrument uses 8 interrupt levels in total (IRQ only). (1) acceptance of interrupt (stored by flip-flop), (2) conversion of interrupt level into 3-bit binary code, (3) interrupt masking (prohibition) and clearing, and (4) entered interrupt are all indicated by LED lamp. 	
4	Auto reset circuit	<ul style="list-style-type: none"> • Effects automatic initial resetting (initialization) if CPU malfunctions due to external noise or momentary power failure. 	
5	61 Hz time base	<ul style="list-style-type: none"> • Generates time base pulse of about 61 Hz by dividing frequency of CPU clock (1 MHz). • Used as reference for interrupt timer and time factor. 	
6	HV I/O port	<ul style="list-style-type: none"> • Turns on/off 30 kV HV power supply and sets voltage value. • Isolated with photocoupler to separate grounding. 	4-13 Fig. 4-16
7	Bus buffer (for option)	<ul style="list-style-type: none"> • Buffer for extending data bus, address bus, etc. to accessory requiring CPU control. • Extends CPU timing (in IC C2) when the device number assigned to accessory is accessed in order to prevent misoperation due to delay of signal via cable. 	4-12
8	Keyboard/display controller	<ul style="list-style-type: none"> • LSI (Intel D8279 or equivalent) reads key switches of operation panel and drives LED display. • Controls all key switches other than MAGNIFICATION and all displays. 	

(Continued)

No.	Circuit	Function	Ref. item No.
9	Toggle switch readout	<ul style="list-style-type: none">• Reads status of lever type selector switches.	
10	Rotary encoder readout	<ul style="list-style-type: none">• Shapes, discriminates (rotation direction), counts and reads FOCUS COARSE rotary encoder output pulse.• Pulses generated along with rotation of encoder are integrated by counter which is read by CPU every 16 ms.	
11	Character display circuit	<ul style="list-style-type: none">• Indicates characters on CRT.• Has a capacity of 32 characters x 32 lines (26 characters x 26 lines used).	3-3-4
12	Condition preset	<ul style="list-style-type: none">• Presets condition with one 8-bit DIP switch and two code switches.• Switch 1 selects power frequency and inputs installed accessory.• Switches 2 and 3 are used for setting factor of corrective calculation for relative magnification error occurring if working distance changes.	

3-3-4 Description of Data Display Circuit

(1) Block composition

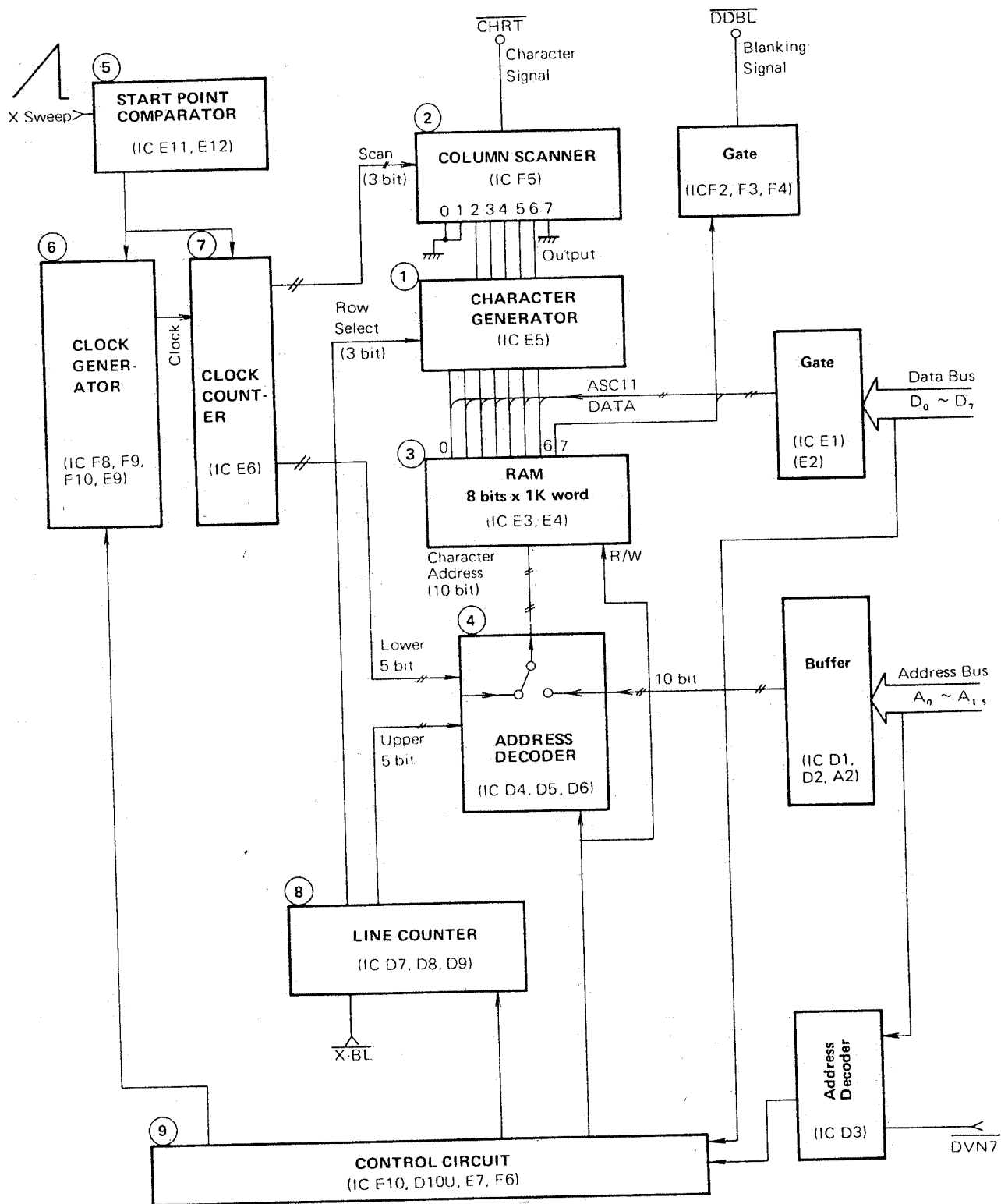

Fig. 3-18 Block Diagram of Data Display Circuit

(2) Function of each circuit component

No.	Circuit	Function	Ref. item No.
1	Character generator (CG)	<ul style="list-style-type: none"> • Generates character pattern of 5 × 8 dots according to input of 7-bit data (the same as in ASCII). • Data on one row out of eight are parallel-output onto 5 output lines according to ROW SELECT input. 	
2	Column scanner	<ul style="list-style-type: none"> • Outputs sequentially 5 data parallel-output from CG and preceding/following blank data (8 data in total) according to SCAN input. 	
3	RAM	<ul style="list-style-type: none"> • Holds character data of 32 characters × 32 lines and outputs 1-character data to CG according to address input. • Address changes during display according to CRT scan. • Address is given from CPU only when writing character data onto RAM. 	
4	Address switch	<ul style="list-style-type: none"> • Selects either clock and line counter output (display) or CPU output (write) of RAM address. • Consists of three 4-bit data selectors. 	
5	Start point comparator	<ul style="list-style-type: none"> • Determines X-directional location from where character display starts. • Selects either rapid or slow scan. 	
6	Clock generator	<ul style="list-style-type: none"> • Generates clock corresponding to X-directional pixels. • Selects any one of 6 oscillators (VCO) of different oscillation frequencies according to X scan speed. 	
7	Clock counter	<ul style="list-style-type: none"> • 8-bit counter ($2^8 = 256$ pixels). • Lower 3 bits drive column scanner (select horizontal dots in 1 character). • Upper 5 bits are connected to lower address of RAM and select character. • Counts up to scale end during horizontal scan and is reset upon completion of horizontal scan. 	
8	Line counter	<ul style="list-style-type: none"> • Integrates X blanking signal (for each horizontal scan line). • Lower 3 bits make row selection for CG, thereby selecting vertical dots in 1 character. • Upper 5 bits are connected to upper address of RAM and select character. • Is reset for each frame. • Maximum count 256. Counting is made after frequency division in IC D8 for scan lines 512, 1024 or 2048. 	

No.	Circuit	Function	Ref. item No.
9	Control circuit	<ul style="list-style-type: none"> Changes over clock frequency, selects frequency dividing ratio of line counter, turns on/off character signal (CHRT) and blanking signal (DDBL), etc. 	

(3) Explanation

1. Generation of character

Each character is composed of 5 (horizontal) × 8 (vertical) dots which are generated in the character generator, abbreviated CG hereinafter.

CG is made up of a mask ROM. It selects a 5 × 8 dot pattern corresponding to any character according to 7-bit input code (whose format is similar to ASCII).

The pattern is formed in such a manner that 5 horizontal dots are output in parallel on one of the 8 vertical rows selected according to RS (Row Select) input of CG.

The figure below shows the pattern of character 5 generated according to \$35 input. In this example, the pattern "11110" on the third row is output because RS input is 011.

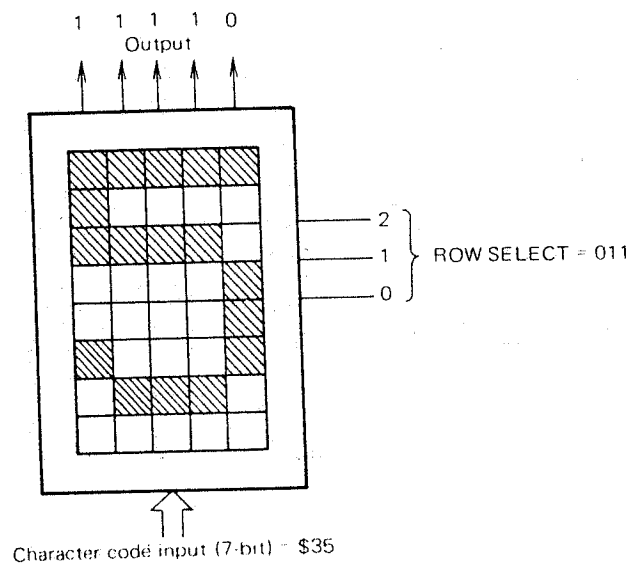

2. Display onto CRT

- ① The CLOCK and LINE counters can be considered a continuous 16-bit counter as illustrated below. It becomes \$0000 at scan start (top left end of character display area) and \$FFFF at scan end (bottom right end of the area). Each section of the counter functions as indicated below.

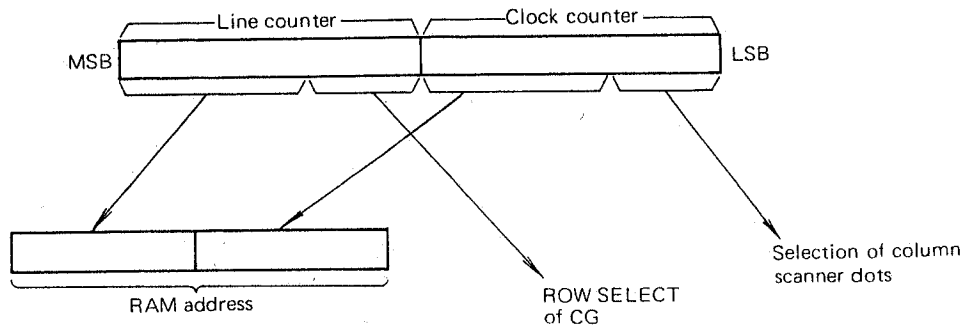

The counter increments by 1 for each horizontal pixel clock from the start to end of character display.

- ② Explanation is given from the first scan.
Since count is zero initially, RAM address corresponds to the first character. Until 8 clocks are input, the dot selecting line of column scanner increases and the signals for the first row of the first character which are output from the CG are sent out in order (3 blank lines are provided before and after 5 CG output lines).
- ③ Since the fourth bit of the counter becomes 1 for the ninth clock, RAM address increments by 1 and the pattern of the second character is output. ROW SELECT of the CG remains zero, so signals for the first row of the second character are sent out in order same as in (2) above.
- ④ In this manner, patterns for the first row of up to thirty-second character are sent out sequentially until the first X scan reaches the end.
- ⑤ In the second X scan, the line counter increments.
Accordingly, the second row of the pattern generated by the CG is sent out sequentially from the first to thirty-second character.
- ⑥ In the ninth X scan, the fourth bit of the line counter becomes 1, whereby the sixth bit of RAM address becomes 1. As a result, the pattern for the thirty-third character is selected. The subsequent characters are sequentially selected and displayed in a similar manner as above.

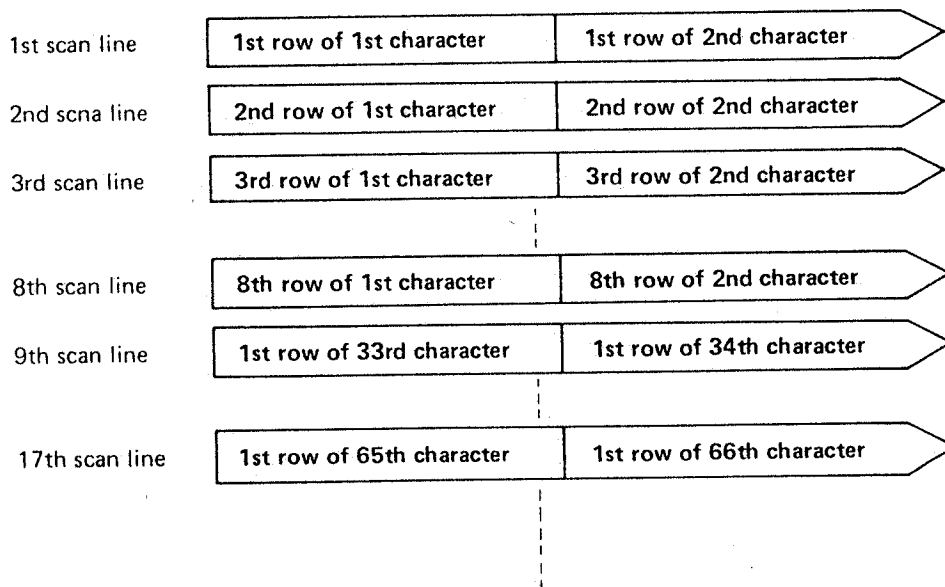

CONTENTS

4. SERVICE INFORMATION	4-1
4-1 Operation and Adjustment of Evacuation System	4-1
4-1-1 Operating Principle	4-1
4-1-2 Operation	4-1
4-1-3 Adjustment	4-1
4-2 Axial Alignment of Electron-Optical System	4-6
4-2-1 Axial Alignment of Electron Gun	4-6
4-2-2 Axial Alignment of Objective Lens Movable Aperture	4-6
4-3 Data for Checking and Adjusting Each Section of Display Unit	4-6
4-3-1 Arrangement of Variable Resistors and Check Terminals	4-6
4-3-2 Function and Adjustment of Each Variable Resistor	4-11
4-3-3 DC Power Supply Unit	4-14
4-3-4 Microcomputer Section	4-16
4-3-5 ANLG Circuit Board and Associated Portions	4-17
4-4 Adjustment of CRT	4-27
4-4-1 Viewing CRT	4-27
4-4-2 Photographing CRT	4-27
4-4-3 Character Display Location	4-28
4-4-4 Rapid Scan	4-29
4-5 Adjustment of Magnification	4-29
4-5-1 Adjustment of Deflecting Point	4-29
4-5-2 Adjustment of Relative Magnification Value after Changing Working Distance	4-29
4-5-3 Adjustment of Orthogonality	4-30
4-5-4 Adjustment of Magnification (Absolute Value)	4-30
4-5-5 Adjustment of Magnification in Rapid Scan	4-30
4-6 Description of CRT and Column Deflection Circuits	4-30
4-7 Adjustment of Lens Circuits	4-34
4-7-1 Objective Lens Circuit	4-34
4-7-2 Condenser Lens Circuit	4-35
4-8 Stigmator Circuit	4-37
4-9 Voltage and Waveform at Each Point of DEF Circuit Board	4-39
4-10 Voltage and Waveform at Each Point of VA Circuit Board	4-40
4-11 High Voltage Circuit	4-41
4-12 Table of Connector Signals	4-44
4-13 Table of I/O Addresses and Signal Functions	4-56
4-14 Service Functions	4-59
4-15 Replacement Device List	4-60
4-16 Check/Adjustment of Motor Drive Unit Components	4-61
4-16-1 Layout of Adjustment Variable Resistors and Check Terminals on Circuit Boards	4-61
4-16-2 Functions and Adjustment Procedures of Variable Resistors	4-62
4-16-3 Voltages at Check Terminals	4-63
4-16-4 Motor Assembly	4-64

4. SERVICE INFORMATION

4-1 Operation and Adjustment of Evacuation System

Fig. 4-1 shows a simplified circuit diagram of the evacuation sequence.

4-1-1 Operating Principle

The evacuation sequence operates according to the status control system utilizing a ROM (ICF11). Opening/closing of each valve is controlled by the logical level of ROM outputs D0 ~ D3 and by the open/close status of the switches A1 ~ A3 provided with valves $\boxed{A1}$ ~ $\boxed{A3}$. When the logical level of D0 ~ D3 is "L", the corresponding valve opens delayed by the capacitor and resistor (C,R). Restriction by the open/close status of the switches A1 ~ A3 is the same between manual and automatic operations.

4-1-2 Operation

Figs. 4-2 and 4-3 show the flowchart of evacuation sequence and the ROM coding table respectively. The water interruption detection circuit will not be activated for a momentary interruption because a delay (of 2 seconds) is provided with capacitor and resistor. The 8-minute timer starts just after the DP warmup thermostat is activated, and after 8 minutes warmup is completed. During warmup, EVAC or AIR switch operation is impossible because it would entail danger.

4-1-3 Adjustment

- (1) Adjustment of full scale of Pirani gauge (atmospheric pressure)
Adjust the meter so as to indicate the full-scale end by moving the VR1 in the Pirani gauge circuit.
- (2) Low/high vacuum changeover
The sequence has been set so that changeover is made when the voltage at the point \textcircled{g} becomes about +1.2 V (fixed).
- (3) Lighting of HIGH lamp
The sequence has been set so as to light the lamp when the voltage at the point \textcircled{g} becomes +0.5 V (fixed).
- (4) Evacuation time
It takes 4 or 5 minutes to attain a high vacuum under which the HIGH lamp is lit starting from the atmospheric pressure.
Fig. 4-4 shows an example of evacuating characteristic.

Details of (A)
When the DP is overheated, turn off the POWER switch for recovery.

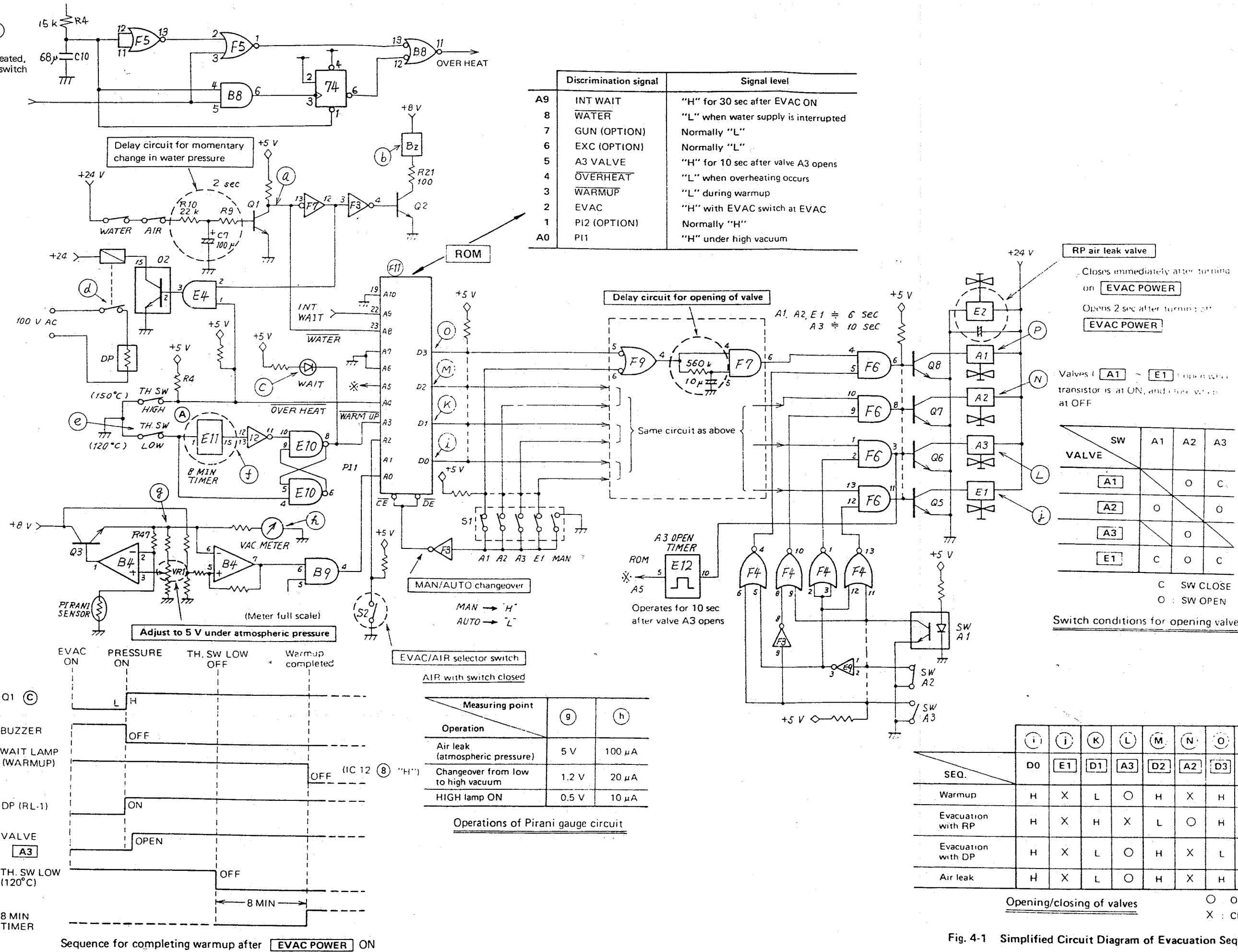

Discrimination signal	Signal level
A9	INT WAIT
8	WATER
7	GUN (OPTION)
6	EXC (OPTION)
5	A3 VALVE
4	OVERHEAT
3	WARMUP
2	EVAC
1	PI2 (OPTION)
A0	PI1

VALVE	SW	A1	A2	A3
A1		O	C	
A2		O		O
A3			O	
E1	C	O	C	

C : SW CLOSE
O : SW OPEN
Switch conditions for opening valve

Measuring point	(g)	(h)
Operation		
Air leak (atmospheric pressure)	5 V	100 μA
Changeover from low to high vacuum	1.2 V	20 μA
HIGH lamp ON	0.5 V	10 μA

Operations of Pirani gauge circuit

SEQ.	(i)	(j)	(K)	(L)	(M)	(N)	(O)	(P)
	D0	E1	D1	A3	D2	A2	D3	A1
Warmup	H	X	L	O	H	X	H	Y
Evacuation with RP	H	X	H	X	L	O	H	X
Evacuation with DP	H	X	L	O	H	X	L	O
Air leak	H	X	L	O	H	X	H	X

Opening/closing of valves
O : Open
X : Close

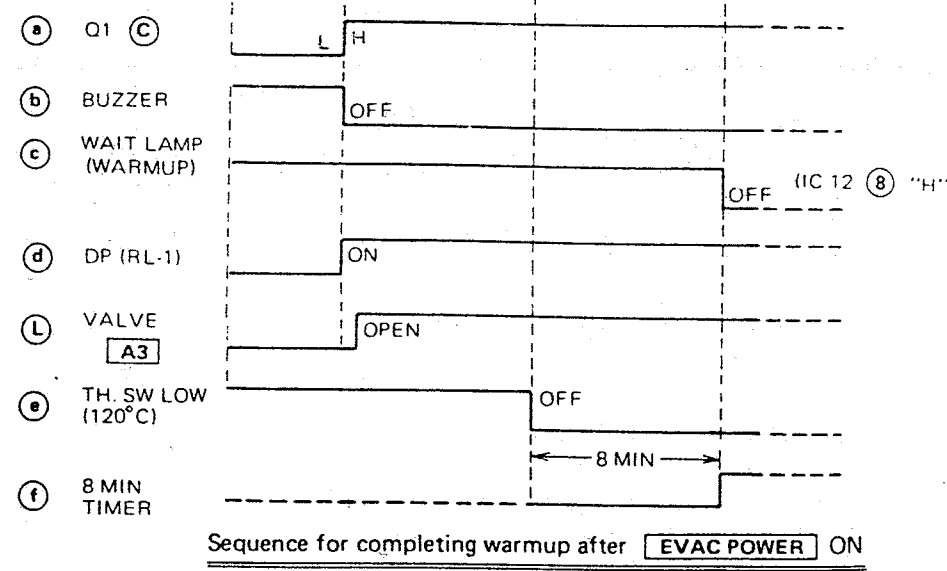

Sequence for completing warmup after EVAC POWER ON

Fig. 4-1 Simplified Circuit Diagram of Evacuation Sequence

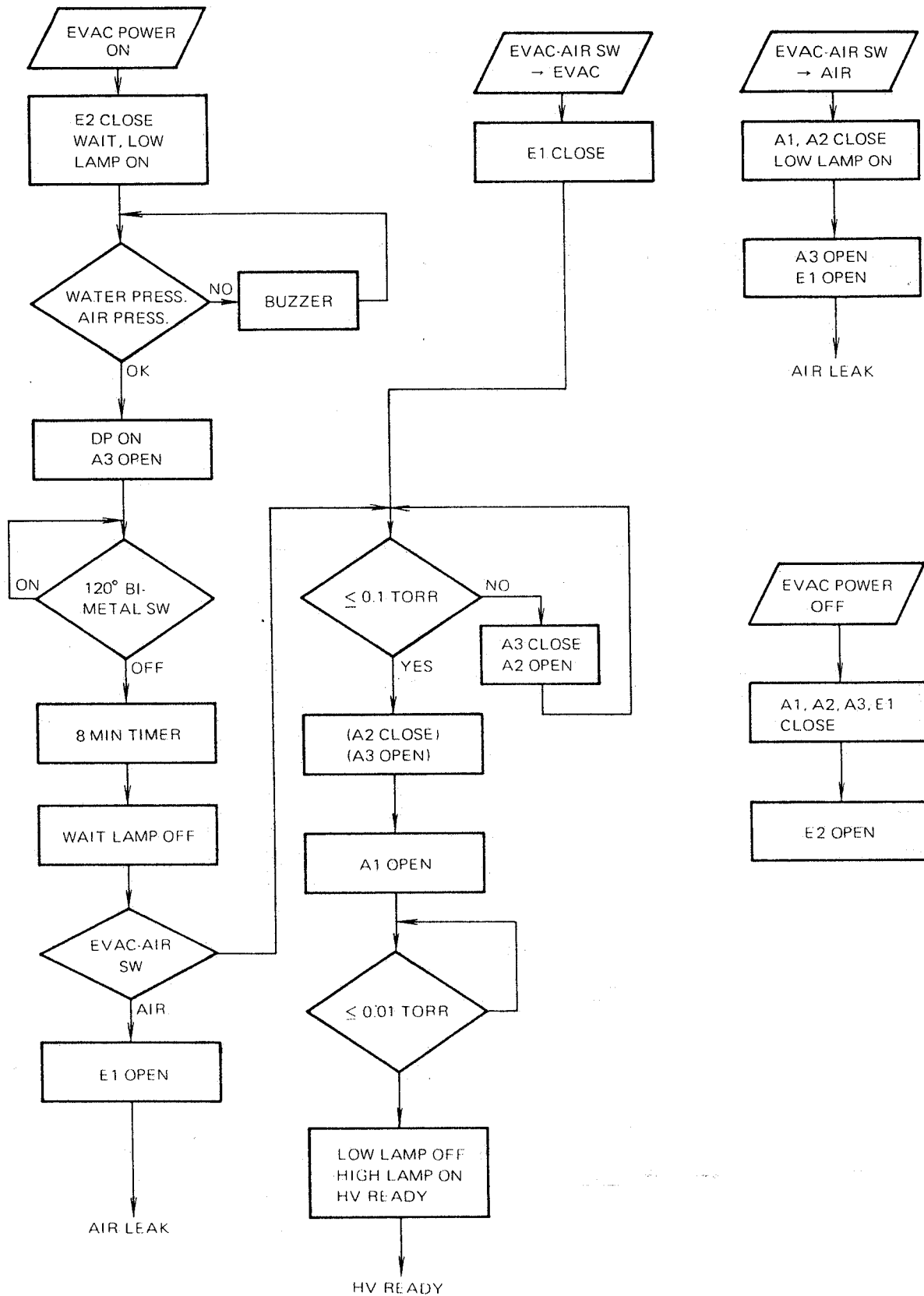

Fig. 4-2 Flowchart of Evacuation Sequence

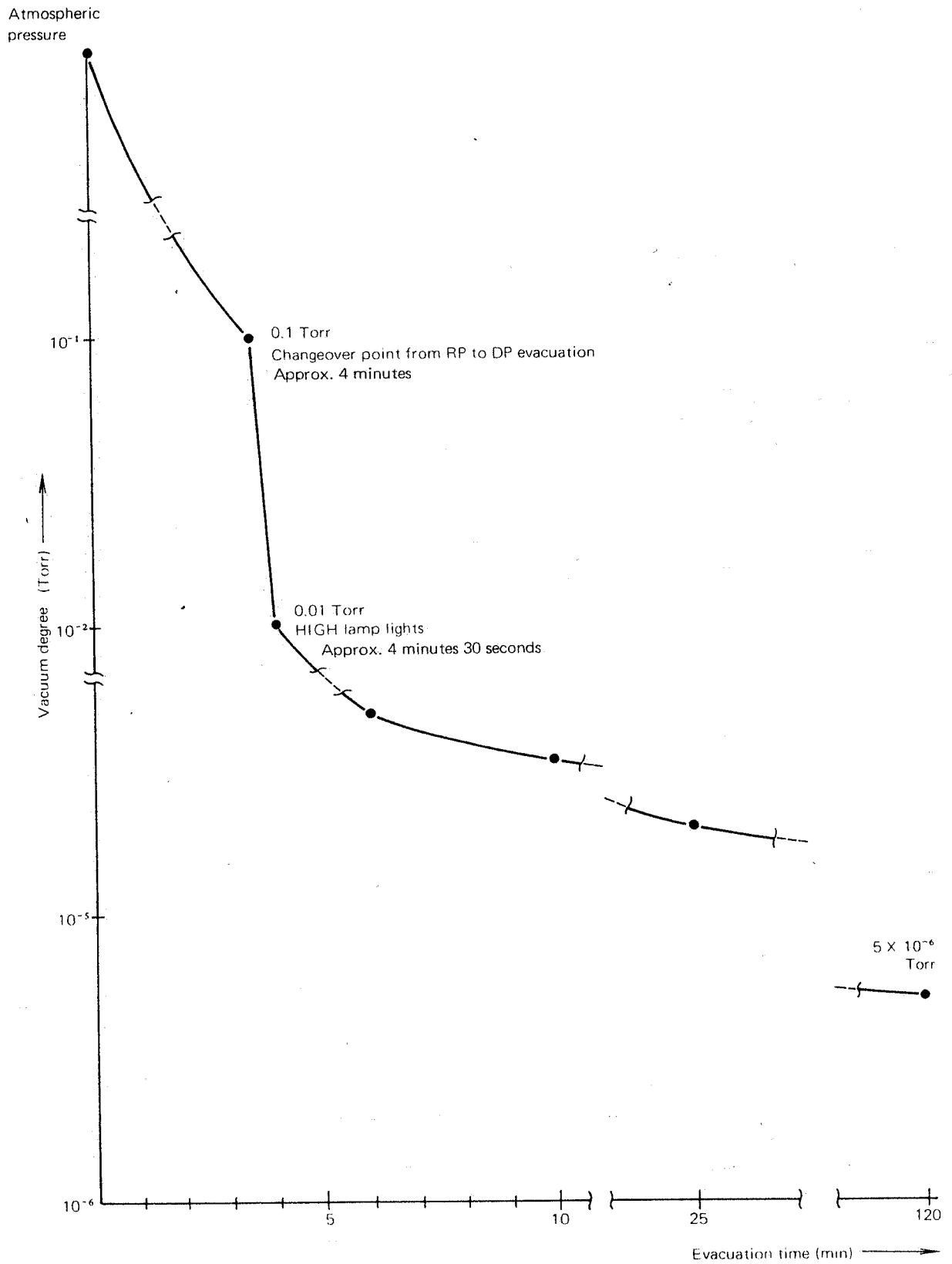

Fig. 4-4 Evacuating Characteristic (Example)

4-2 Axial Alignment of Electron-Optical System

Since the instrument detects secondary electrons from above the objective lens as well as from below it, the objective lens movable aperture is placed between the deflection coil and condenser lens. This system is less affected by contamination because the influence of aperture contamination is suppressed due to the objective lens. If the optical axis of the condenser lens is misaligned, however, the objective lens movable aperture may be deviated from the center of the objective lens. So, the system requires more careful axial alignment than the conventional instruments.

The first and second condenser lens currents are set independent of each other for the following reason. Current value is to be adjusted usually for the first condenser lens alone, maintaining constant the focal point of the second condenser lens in order to prevent a deviation from the optical axis.

4-2-1 Axial Alignment of Electron Gun

For procedure, refer to the instruction manual.

In cases where almost the same accelerating voltage and probe current are always utilized, this alignment does not require an extremely high precision. It is usually adequate to adjust the **GUN ALIGNMENT HORIZ (X), (Y)** controls so as to obtain maximum brightness.

4-2-2 Axial Alignment of Objective Lens Movable Aperture

Misalignment of the objective lens movable aperture exerts a large influence on image resolution. This instrument has a greater chance of misalignment than the conventional instruments. To cope with this, it is requested to instruct the customer to check misalignment under the APT ALIGN mode in the following cases.

- (a) After changing accelerating voltage or condenser lens current
- (b) After changing over **SED** or **STAGE** switch position (Except for S-2500C)
- (c) If resolution is poor

For procedure, refer to the instruction manual.

4-3 Data for Checking and Adjusting Each Section of Display Unit

4-3-1 Arrangement of Variable Resistors and Check Terminals

Figs. 4-5 through 4-8 show the arrangement of the adjusting variable resistors and check terminals of each circuit board.

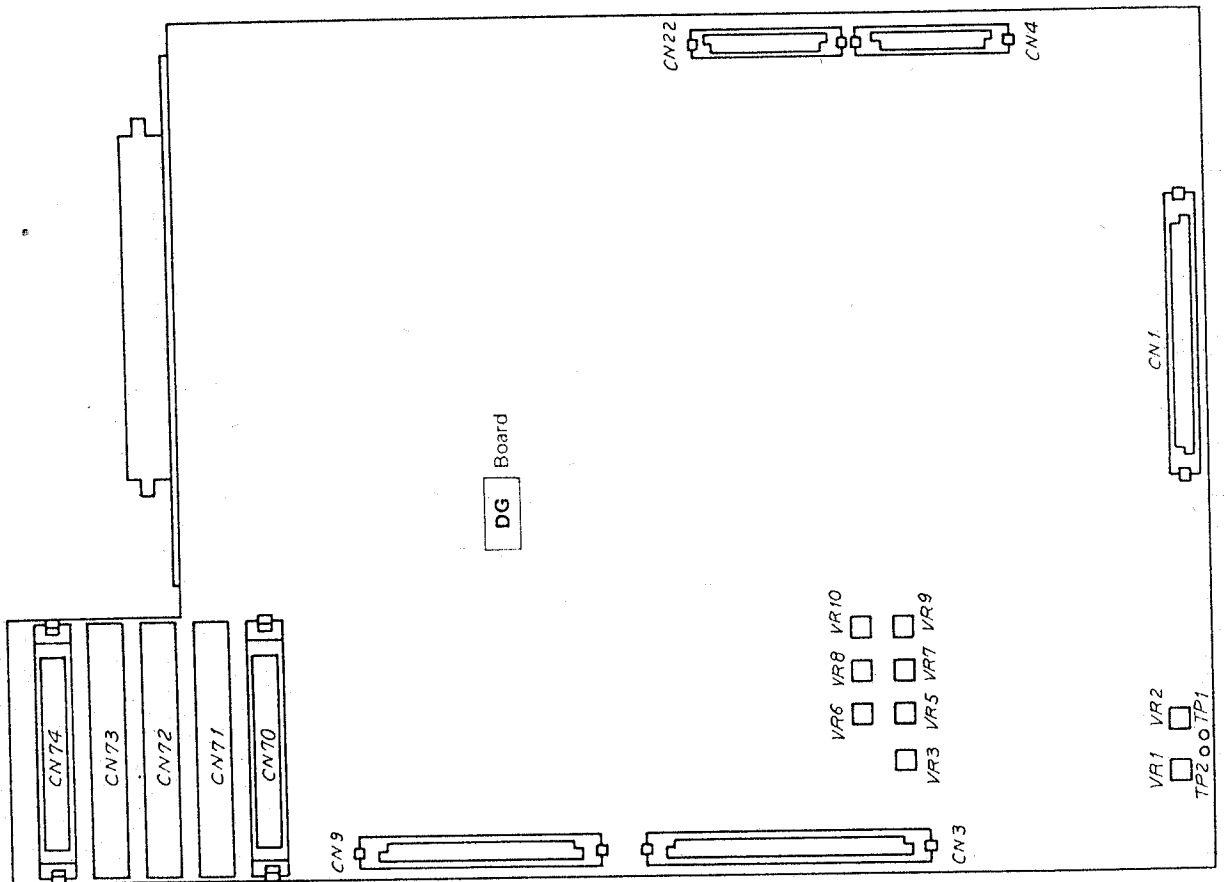
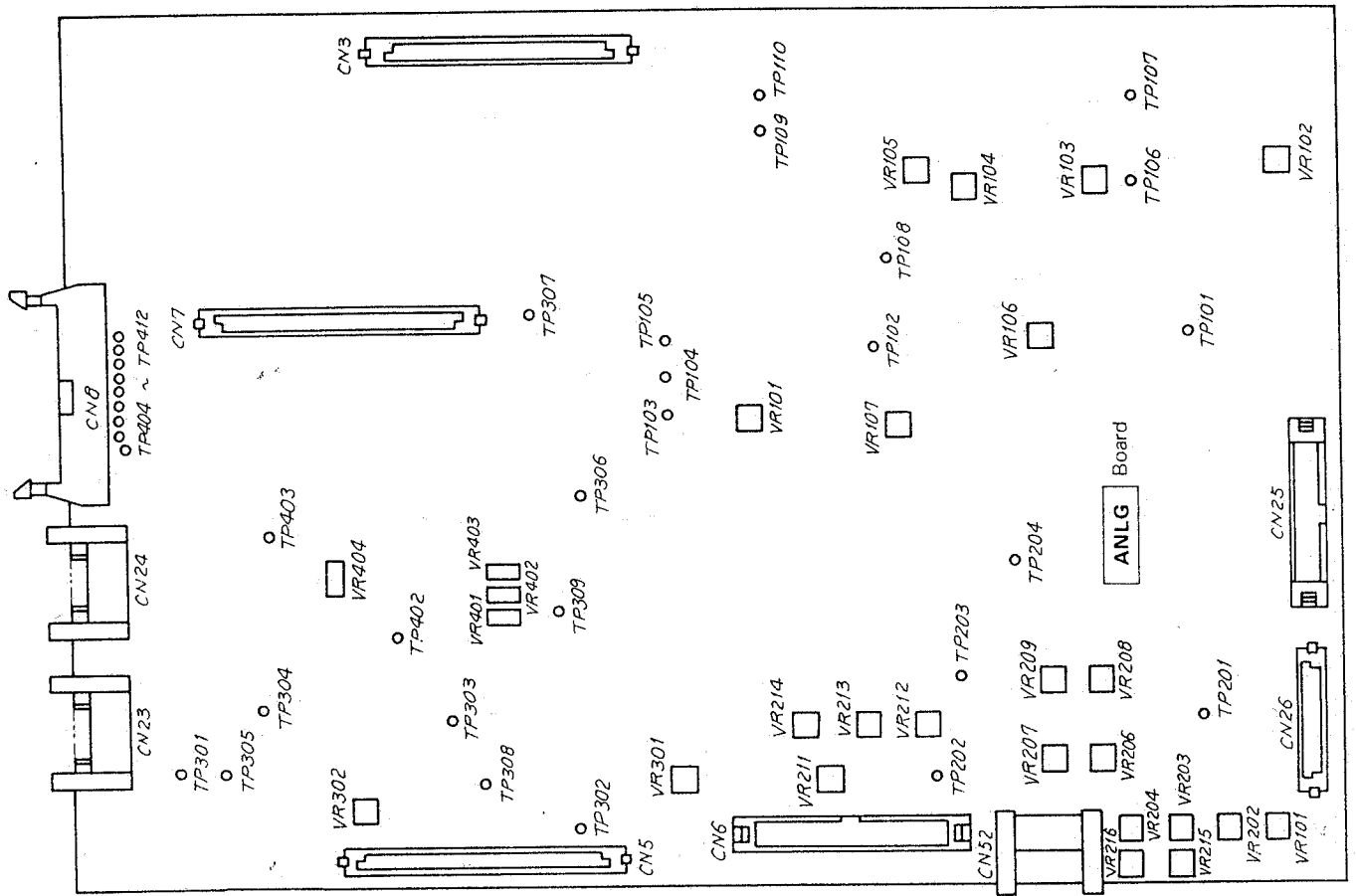

Fig. 4-5 Arrangement of Adjusting Variable Resistors and Check Terminals (1)

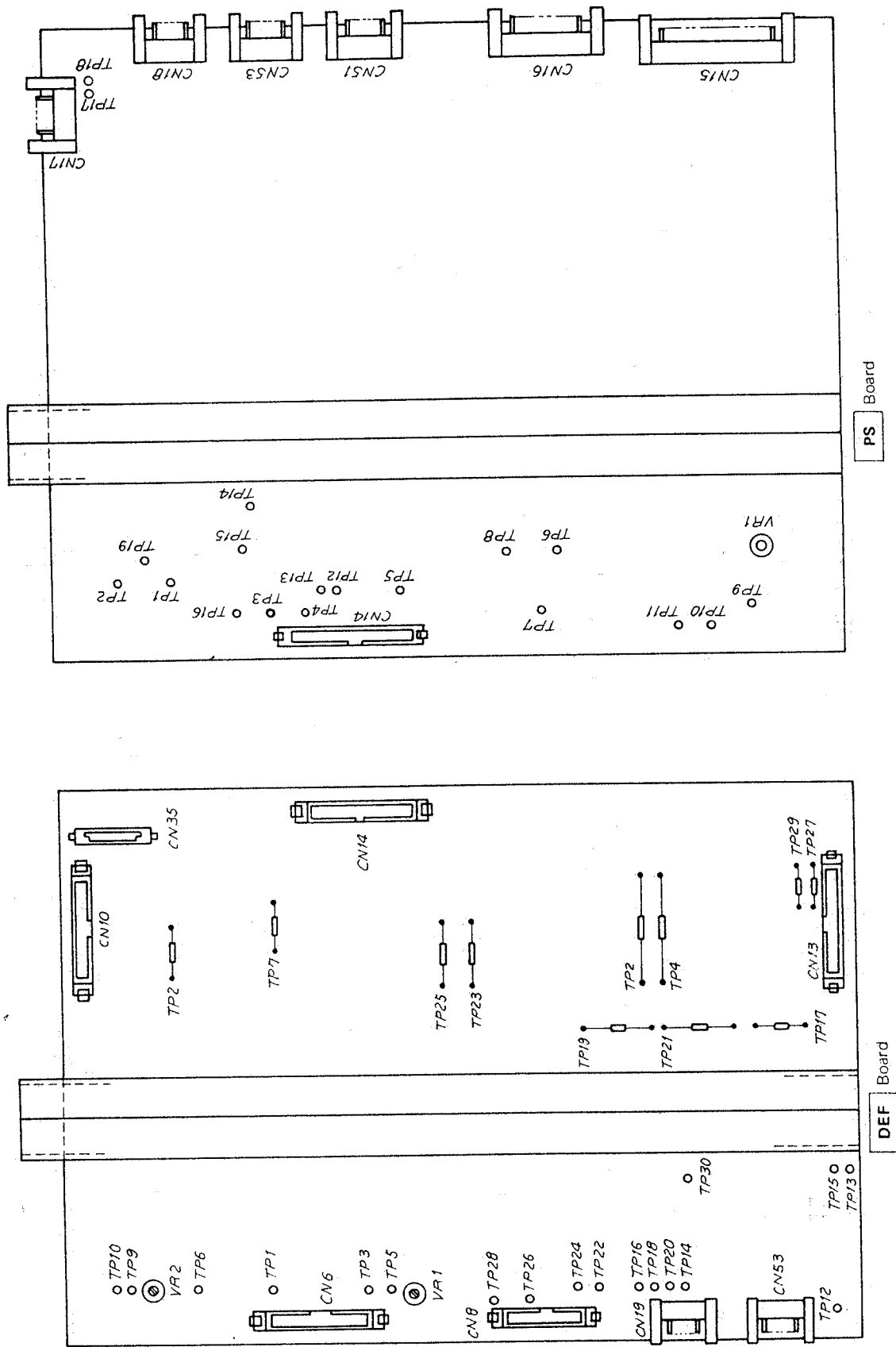

Fig. 4-6 Arrangement of Adjusting Variable Resistors and Check Terminals (2)

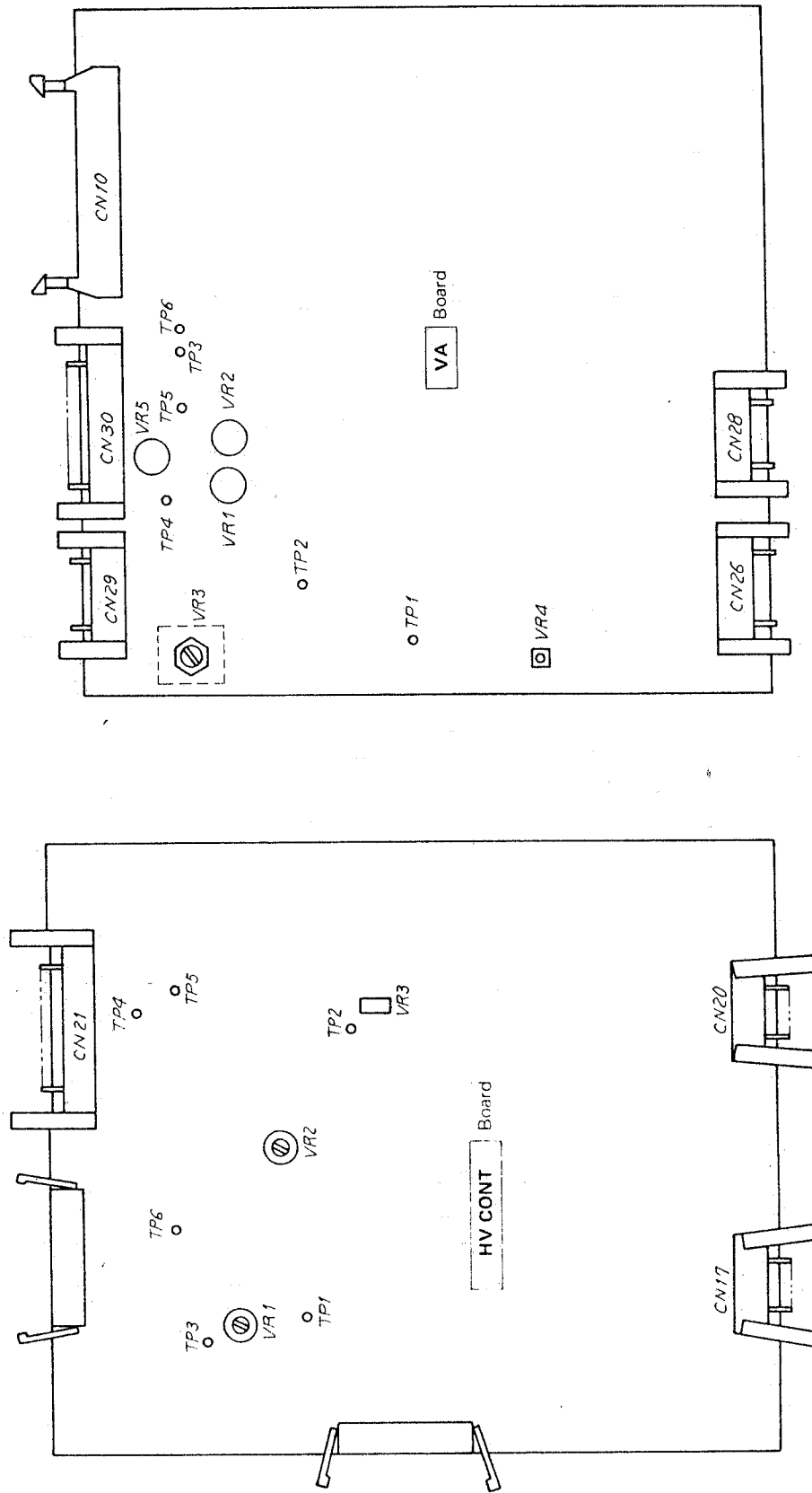

Fig. 4-7 Arrangement of Adjusting Variable Resistors and Check Terminals (3)

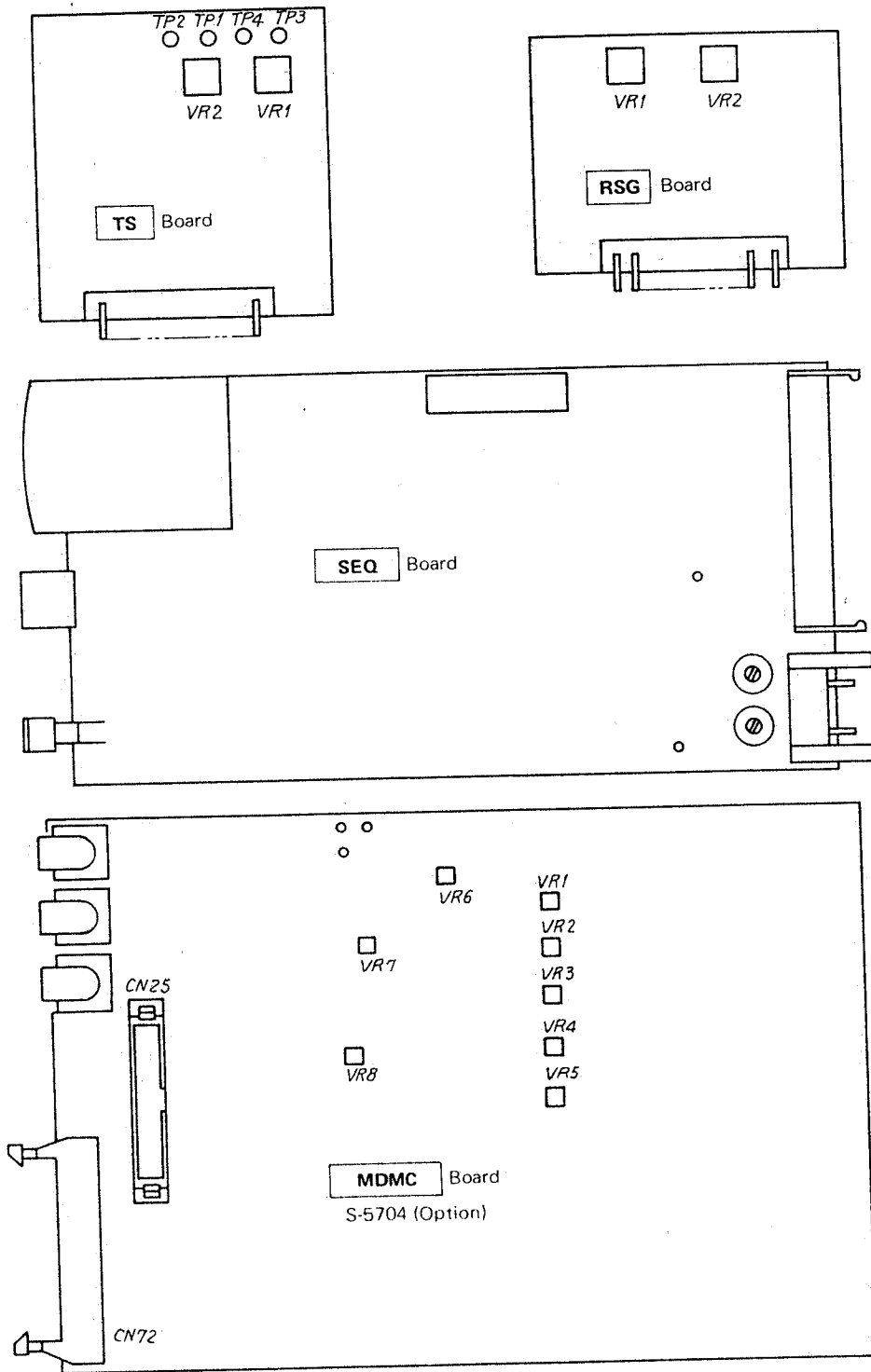

Fig. 4-8 Arrangement of Adjusting Variable Resistors and Check Terminals (4)

4-3-2 Function and Adjustment of Each Variable Resistor

(1) DG circuit board

VR No.	Function	Adjustment or Ref. item No.	Arrangement
VR1	Adjusts level (duty ratio) of pulse output from FOCUS-COARSE rotary encoder	4-7-1	Fig. 4-5
VR2	Adjusts level (duty ratio) of pulse output from FOCUS-COARSE rotary encoder	4-7-1	
VR3	Adjust width of data display	At scan speed PHOTO 3	
VR5		At scan speed 3	
VR6		At scan speed 4	
VR7		At scan speed RAPID	
VR8		At scan speeds 1 , 2	
VR9	Adjusts location (left and right) of data display (at scan speed RAPID)		
VR10	Adjusts location (left and right) of data display (at scan speeds 1 ~ 4 , PHOTO)		

(2) ANLG circuit board

VR No.	Function	Adjustment or Ref. item No.	Arrangement
VR101	Adjusts amplitude of Y_C output (oscillation occurs in auto focus only)	4-3-5	Fig. 4-5
VR102	Adjusts X scan speed (any of 3 , 4 , PHOTO)	4-3-5	
VR103	Adjusts X scan speed (1)	4-3-5	
VR104	Adjusts interlace at scan speed RAPID	Adjust so as to provide uniform intervals between scan lines at RAPID	
VR105	Adjusts X scan speed (RAPID)	4-3-5	
VR106	Adjusts no. of Y scan lines (at scan speeds 2 , 4)	4-3-5	
VR107	Adjusts no. of Y scan lines (at scan speeds 1 , 3)	4-3-5	

VR No.	Function	Adjustment or Ref. item No.	Arrangement
VR201	Adjusts X width of viewing CRT	4-4-1	Fig. 4-5
VR202	Adjusts X width of photo CRT	4-4-2	
VR203	Adjusts X location of viewing CRT	4-4-1	
VR204	Adjusts X location of photo CRT	4-4-2	
VR205			
VR206	Adjusts Y location of viewing CRT	4-4-1	
VR207	Adjusts Y width of viewing CRT	4-4-1	
VR208	Adjusts Y location of photo CRT	4-4-2	
VR209	Adjusts Y width of photo CRT	4-4-2	
VR211	Adjusts X amplitude of viewing CRT at scan speed RAPID	4-5-5	
VR212	Corrects orthogonality	Adjust so that image is orthogonally positioned using an orthogonal specimen (such as grid)	
VR213	Adjusts Y-directional magnification with STAGE at LOWER	↑	
VR214	Adjusts X-directional magnification with STAGE at LOWER	↑	
VR215	Adjusts X-directional magnification with STAGE at UPPER	↑	
VR216	Adjusts Y-directional magnification with STAGE at UPPER	↑	
VR301	Adjusts contrast set for ABCC	4-3-5	
VR302	Adjusts convergent speed in ABCC	4-3-5	
VR401	Adjusts focus with STAGE at LOWER (on lower current side)	4-7-1	
VR402	Adjusts focus with STAGE at UPPER (on lower current side)	4-7-1	
VR403	Adjusts focus with STAGE at LOWER (on higher current side)	4-7-1	
VR404	Adjusts focus with STAGE at UPPER (on higher current side)	4-7-1	

(3) RSG circuit board

VR No.	Function	Adjustment or Ref. item No.	Arrangement
VR1	Adjusts X-directional magnification at scan speed RAPID	Adjust so as to match X-directional magnification and image location with those at scan speed 1	Fig. 4-8
VR2	Adjusts X-directional location at scan speed RAPID		

(4) DEF and TS circuit boards

VR No.	Function	Adjustment or Ref. item No.	Arrangement
(DEF) VR1	Adjusts offset of Y-modulation signal for dynamic focus	Adjust TP5 voltage to 0 V at maximum magnification	Fig. 4-6
VR2	Adjusts offset of column X deflection circuit	Adjust so that movement of magnification center is minimized at changeover point of relay, while altering magnification	
(TS) VR1	Adjusts zero point of objective lens temperature detecting thermistor		Fig. 4-8
VR2	Adjusts zero point of thermistor circuit for detecting DEF circuit board heat sink temperature		

(5) PS circuit board

VR No.	Function	Adjustment or Ref. item No.	Arrangement
VR1	Adjusts +110 V output	Adjust voltage between TP19 (+) and TP15 (G) to 110 V	Fig. 4-6

(6) VA circuit board

VR No.	Function	Adjustment or Ref. item No.	Arrangement
VR1	Adjusts brightness of viewing CRT	For adjustment, turn the VIEW CRT BRIGHT knob (inside the cover) to 12 o'clock position.	Fig. 4-7

VR No.	Function	Adjustment or Ref. item No.	Arrangement
VR2	Adjusts brightness of photo CRT (coarsely)	For adjustment, turn the PHOTO CRT CONTRAST, BRIGHT trimmer and ABC CONTRAST knobs (inside the cover) to 12 o'clock positions.	Fig. 4-7
VR3	Adjusts focus of photo CRT (standard CRT)		
VR4	Adjusts offset of video amplifier	Adjust TP1 voltage to 0 V with CN26 (SE amp) disconnected	
VR5	Adjusts brightness of photo CRT (finely)		

(7) HVC circuit board

VR No.	Function	Adjustment or Ref. item No.	Arrangement
VR1	Adjusts accelerating voltage finely	(Do not move)	Fig. 4-7
VR2	Adjusts excitation frequency	Adjust to 30 kHz	
VR3	Adjusts preset filament current	<ul style="list-style-type: none"> • Hairpin W filament Set so as to saturate with operation panel control knob at 2 ~ 3 o'clock position • LaB₆ filament Adjust so as to obtain determined current with operation panel FILAMENT knob at maximum position 	

4-3-3 DC Power Supply Unit

Table 4-1 lists the specifications of the DC power supply unit (PS circuit board). Power supplies other than asterisked are all stabilized and provided with short-circuit protection (hold-back system). Only the 110 V power supply for CRT bias requires adjustment, while others are fixed.

Table 4-1 Specifications of DC Power Supply Unit

Load circuit	Rated output	Input AC (nominal value)	Rectified output	Output voltage	Max. current	Short-circuit current	Rectification ripple	Output ripple	(Load resistance)	Measuring point	
										TP	CN14
*RAPID deflection	45 V 1 A	45 V 2.3 A		62~68 V					68 Ω (100 W)	D1 ⊕ - TP2	Ⓣ - Ⓢ
COL X deflection	40 V 1.5 A			41 ± 1 V	1.9 ± 0.2 A	0.9 ± 0.1 A			27 Ω (100 W)	TP1 - TP2	Ⓜ - Ⓢ
COL Y and CRT X deflections	25 V 2.5 A	31 V 2.8 A		25 ± 1 V	2.9 ± 0.3 A	1.3 ± 0.2 A			10 Ω (100 W)	TP3 - TP4	Ⓛ - Ⓢ
COL X/Y and CRT X deflections	-25 V 3.5 A	31 V 3.8 A		-25 ± 1 V	3.7 ± 0.4 A	1.3 ± 0.2 A			8.2 Ω (100 W)	TP4 - TP5	Ⓢ - Ⓚ
CRT Y deflection	15 V 2.5 A	19.5 V 2.8 A		15 ± 1 V	2.8 ± 0.3 A	1.4 ± 0.2 A			6 Ω (50 W)	TP6 - TP7	Ⓝ - Ⓢ
SG circuit	-15 V 2.5 A	19.5 V 2.8 A		-15 ± 1 V	2.8 ± 0.3 A	1.4 ± 0.2 A			6 Ω (50 W)	TP7 - TP8	Ⓢ - Ⓢ
Lens circuit	15 V 2.5 A	19.5 V 2.8 A		15 ± 1 V	2.8 ± 0.3 A	1.4 ± 0.2 A			6 Ω (50 W)	TP9 - TP10	ⓕ - Ⓢ
	-15 V 2.5 A	19.5 V 2.8 A		-15 ± 1 V	2.8 ± 0.3 A	1.4 ± 0.2 A			6 Ω (50 W)	TP10 - TP11	Ⓢ - Ⓢ
*Lens B power supply	40 V 3.5 A	42 V 4 A		60 ~ 66 V					15 Ω (300 W)	TP12 - TP13	Ⓢ - Ⓢ
Video amp circuit	15 V 2 A	19 V 2.2 A		15 ± 1 V	2.3 ± 0.2 A	1.4 ± 0.2 A			8.2 Ω (50 W)	TP14 - TP15	Ⓢ - Ⓢ
	-15 V 1 A	19 V 1.2 A		-15 ± 1 V	1.2 ± 0.1 A	0.7 ± 0.1 A			15 Ω (30 W)	TP15 - TP16	Ⓢ - Ⓢ
*10K HV power supply	24 V 0.5 A	23 V 0.6 A		32 ~ 36 V					68 Ω (20 W)	TP17 - TP18	Ⓝ17 Ⓢ - Ⓢ
CRT bias	110 V 10 mA	120 V 30 mA		110 ± 2 V (requires adjustment)		45 ± 5 mA			10 kΩ (3 W)	TP19 - TP15	Ⓢ - Ⓢ
*For lamp	AC 6.5 V 0.5 A	6.5 V 0.5 A		AC 6.5 ± 1 V					-	Lamp terminal	

(1) 110 V, 10 mA power supply voltage needs to be adjusted (with VR1).

4-3-4 Microcomputer Section

The microcomputer used in this instrument is assembled on two circuit boards including the memory. (6809 CPU, 6809 MEM)

(1) Specifications

- ① Microprocessor : HD6809 (MC6809)
- ② Clock frequency : 1 MHz
- ③ RAM capacity : 4K bytes (8K bytes possible)
(with battery backup)
- ④ ROM capacity : 16K bytes
- ⑤ Program capacity : About 16K bytes
- ⑥ Interruption : 8-level IRQ + NMI

(2) Address assignment (total address capacity 64K bytes)

- ① RAM area : $(0000)_{16}$ to $(1FFF)_{16}$
- ② ROM area : $(C000)_{16}$ to $(FFFF)_{16}$
- ③ I/O address : $(8000)_{16}$ to $(87FF)_{16}$





(3) Interruption

Although interruption is possible up to 8 levels, 7 levels are used.

- ① INT0 : Timer (61 Hz) interruption
- ② INT1 : CST (for each cycle of X_C signal, auto focus)
- ③ INT2 : When operation panel switch is pressed
- ④ INT3 : ABC end (when both contrast and brightness enter allowable range in ABC)
- ⑤ INT4 : When any key of Model S-6501 data entry keyboard is pressed
- ⑥ INT5 : X blanking signal
- ⑦ INT6 : Y blanking signal (for indicating completion of photo scan and refreshing data in each section)
- ⑧ INT7 : Split signal (generated at central dividing point of CRT in split screen mode)

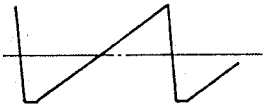
4-3-5 ANLG Circuit Board and Associated Portions

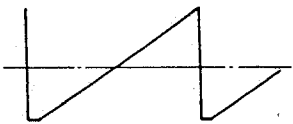
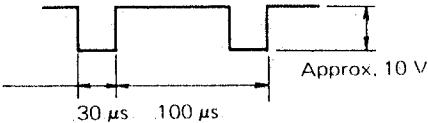
(1) Voltage and waveform at each point of sweep generator

Check Point	Item	Voltage and Waveform	
IC B19U ①	Reference voltage	-10 V ± 0.5 V	
IC B19U ⑦ IC B19L ⑦	X-amplitude reference voltage Y-amplitude reference voltage	<ul style="list-style-type: none"> -10 V except for scan speed REDUCE 	<ul style="list-style-type: none"> -3.4 V for scan speed REDUCE
TP101	X sweep	<ul style="list-style-type: none"> Mode: NORM, W. FORM, OBLIQUE Scan speed: Other than RAPID  <p>(For period and amplitude, refer to "scan speed")</p>	<ul style="list-style-type: none"> Mode: Same as left Scan speed: RAPID  -8.5 V
TP102	Y sweep	<ul style="list-style-type: none"> Mode: ALL Scan speed: ALL  <p>(For period and amplitude, refer to "scan speed")</p>	
TP107	Rapid scan signal	<ul style="list-style-type: none"> Mode: NORMAL Scan speed: RAPID  <p>Approx. 10 V</p> <p>30 μs 100 μs</p>	<ul style="list-style-type: none"> In other than at left  Approx. 0 V

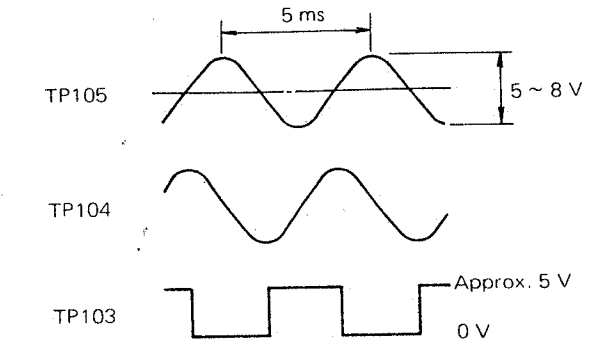
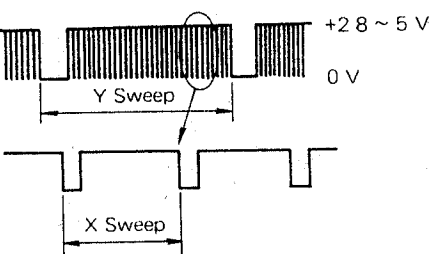
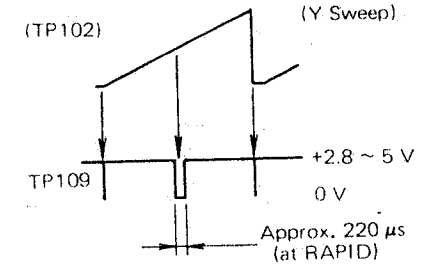
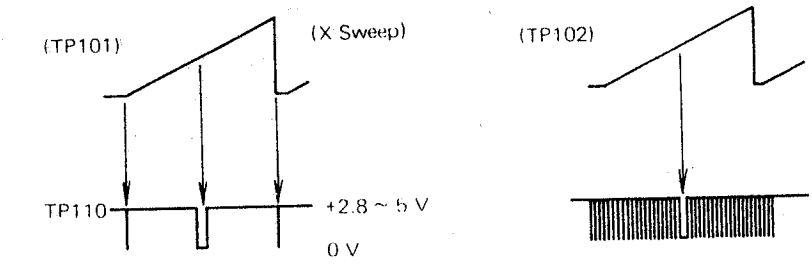
Check Point	Item	Voltage and Waveform
TP105 TP104 TP103	Auto focus scan	<ul style="list-style-type: none">• In auto focus mode only  <p>TP105: 5 ms, 5 ~ 8 V</p> <p>TP104</p> <p>TP103: Approx. 5 V, 0 V</p>
TP108	Blanking signal	 <p>+2.8 ~ 5 V</p> <p>0 V</p> <p>Y Sweep</p> <p>X Sweep</p>
TP109	Split blanking signal	<ul style="list-style-type: none">• Mode: SPLIT  <p>(TP102) (Y Sweep)</p> <p>TP109: +2.8 ~ 5 V, 0 V</p> <p>Approx. 220 μs (at RAPID)</p>
TP110	BU (cross mark signal)	<ul style="list-style-type: none">• Mode: STIG. MONITOR  <p>(TP101) (X Sweep)</p> <p>TP110: +2.8 ~ 5 V, 0 V</p> <p>(TP102)</p>

(2) Adjustment of scan speed

X scan speed is adjusted by changing input current to the Miller integrator circuit (IC C20-C101). Scan speeds lower than 20 (17) ms are changed over by altering data of the D/A converter (IC B20). The data are given different values according to the power frequency (50/60 Hz). So there is no need for readjustment after reconnecting a power supply, unlike with the conventional instruments.

As for Y scan speed, the step width of integrator output voltage is changed by adjusting the value of the pulse current to be flowed through the integrator circuit (IC C16-C102) for each X scan, and at the same time the number of steps (scan lines) for each Y scan is adjusted by changing the gain of the amplifier (IC C14, IC C16) provided between the integrator output and the comparator which determines the amplitude.

Frequency is changeable through setting of the switch 1 (shown below) of the **DG** circuit board. In this case, replace 223 (50 Hz) C3 with 153 (60 Hz) C3.

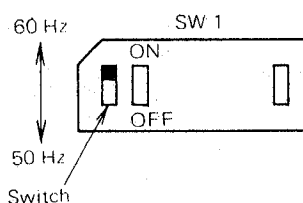

X Scan Speed

Mode	Scan Speed	Check Pt.	Waveform	50 Hz	60 Hz	Amplitude	Adjust	
NORMAL	1, 2	TP101		1 ms 0.1 ms	←	± 8.5 V	VR103	
	3			20 ms 4 ms	16.7 ms 4 ms	± 8.5 V	(VR102)	
	4			40 ms 4 ms	50 ms 4 ms	± 8.5 V	VR102	
	REDUCE			0.3 ms 0.1 ms	←	± 2.9 V	(VR103)	
NORMAL (PHOTO)	1			20 ms 4 ms	16.7 ms 4 ms	± 8.5 V	(VR102)	
	2			40 ms 4 ms	50 ms 4 ms	± 8.5 V	(VR102)	
	3, 4			100 ms 4 ms	100 ms 4 ms	± 8.5 V	(VR102)	
WAVE FORM					100 ms 4 ms	100 ms 4 ms	± 8.5 V	(VR102)

- Notes: 1. VR102 must be adjusted at scan speed **4**.
 2. When adjusting both VR102 and VR103, VR102 must be adjusted first.

Y Scan Speed

Mode	Scan Speed	Check Pt.	Waveform	Number of Line	Ty (50 Hz)	Ty (60 Hz)	Amplitude	Adjust
NORMAL	RAPID	TP102		250	35 frames/sec	←	±10 V	
	1			500	0.5 s	←	±10 V	VR107
	2			1000	1 s	←	±10 V	VR106
	3			500	10 s	8.3 s	±10 V	
	4			1000	40 s	50 s	±10 V	
	REDUCE (FAST)			(170)			±3.4 V	
	REDUCE (SLOW)			(340)			±3.4 V	
	NORMAL (PHOTO)			1		2000	40 s	34 s
2			2000	80 s	100 s	±10 V		
3			2000	200 s	200 s	±10 V		
4			2000	400 s	400 s	±10 V		
			2000 X2 (Repeat)					

Note: Make adjustment first at scan speed **2**, and then at **1**.
(Other scan speeds depend on these adjustments.)

(3) Description of sweep generator circuit

Figs. 4-9 and 4-10 show a simplified circuit diagram of the X and Y sweep generators.

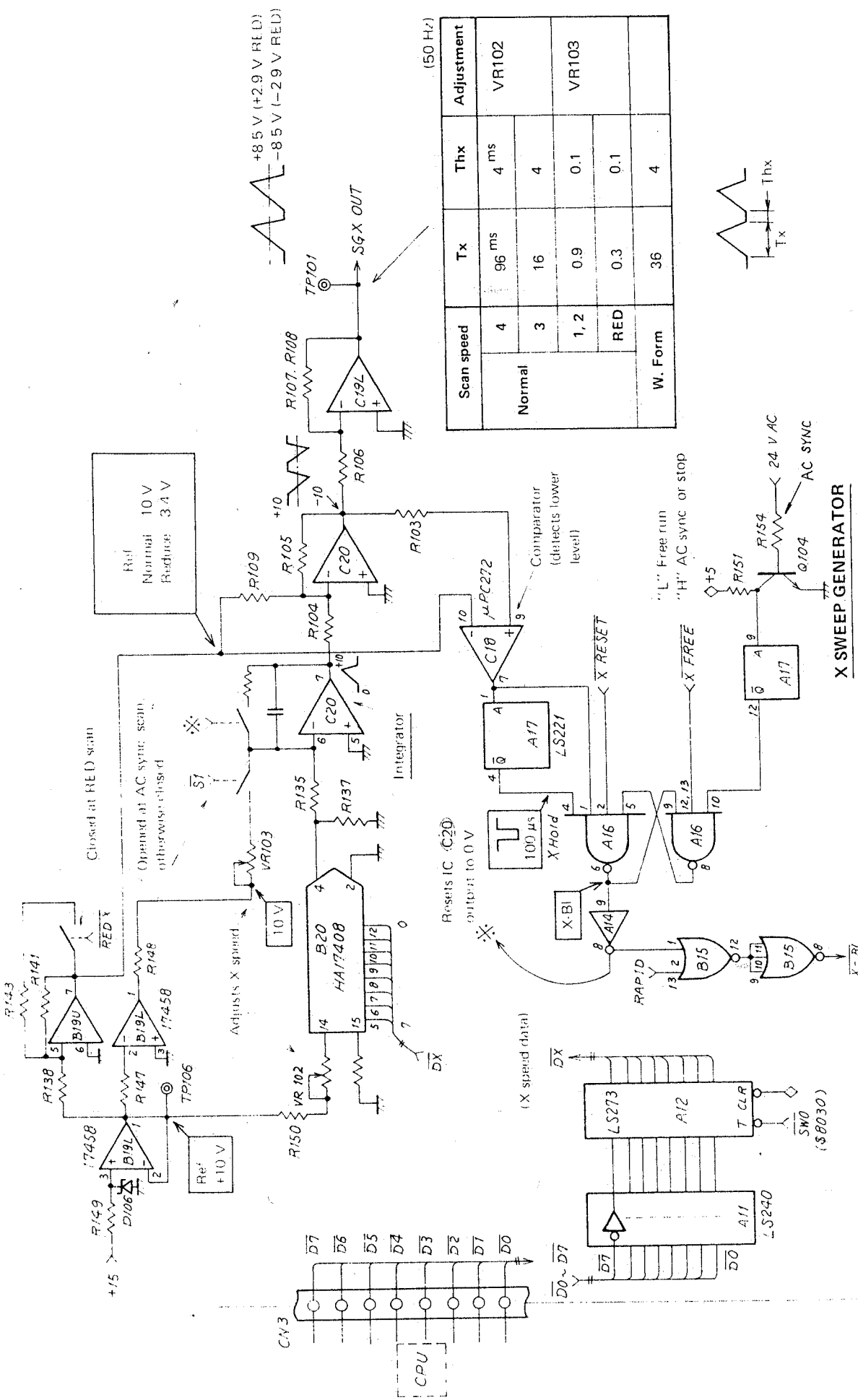
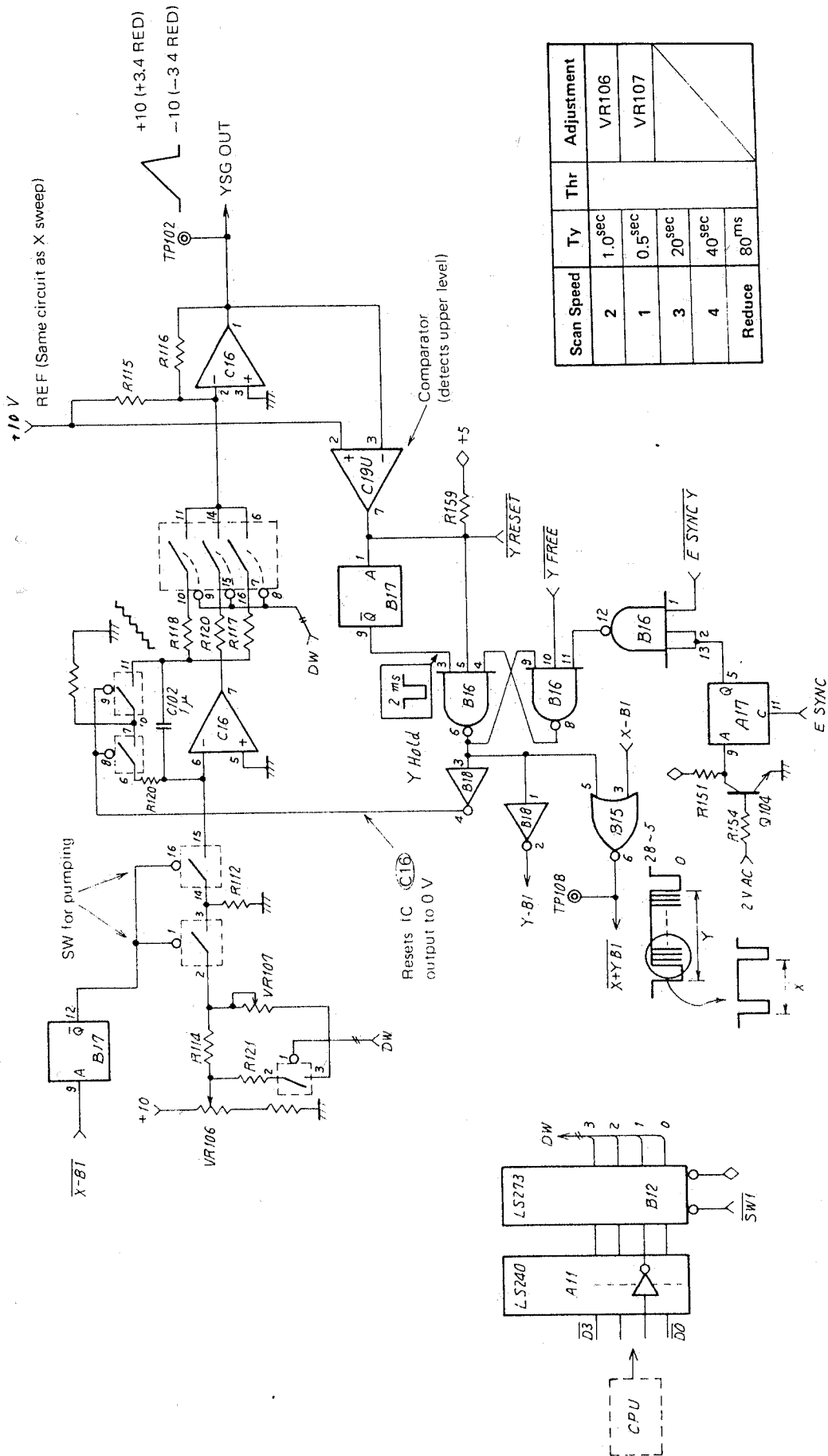

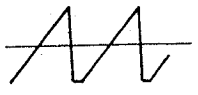
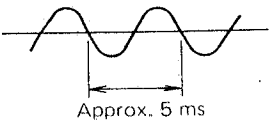
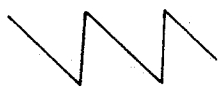
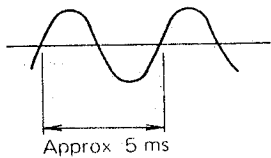

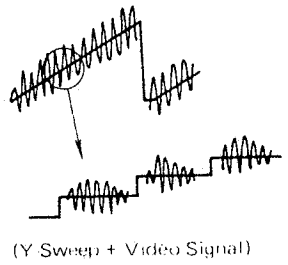

Fig. 4-9 Simplified Circuit Diagram of X Sweep Generator





Y SWEEP GENERATOR (ANLG)

Fig. 4-10 Simplified Circuit Diagram of Y Sweep Generator

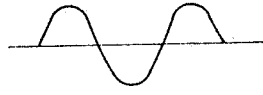

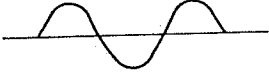

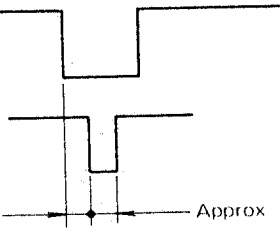

(4) Voltage and waveform at each point of mode control unit

Check Point	Item	Voltage and Waveform	
TP201	CRT X sweep signal	<ul style="list-style-type: none"> • Mode: NORM, W. FORM, OBLIQUE • Scan: Other than RAPID  <p>Amplitude changeable from 10 to 20 Vp-p with VR201 (viewing CRT) or VR202 (photo CRT)</p>	<ul style="list-style-type: none"> • Auto focus 
TP204	CRT Y sweep signal	<ul style="list-style-type: none"> • Mode: NORM  <p>Amplitude variable from 10 to 20 Vp-p with VR207 (viewing CRT) or VR209 (photo CRT)</p>	<ul style="list-style-type: none"> • Auto focus 
		<ul style="list-style-type: none"> • Mode: W. FORM, FOCUS SEARCH 	<ul style="list-style-type: none"> • Mode: OBLIQUE 
TP203	Column X sweep signal	<ul style="list-style-type: none"> • Mode: NORMAL, W. FORM, OBLIQUE  <p>Amplitude changes by about 1 digit throughout magnification range, and is variable with VR214 (with STAGE at LOWER) or VR215 (with STAGE at UPPER) * VR212 superimposes Y waveform (for correcting orthogonality of image).</p>	<ul style="list-style-type: none"> • Auto focus  <hr/> <p>Approx. 0 V</p> <ul style="list-style-type: none"> • Mode: W. FORM, FOCUS SEARCH

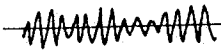
Check Point	Item	Voltage and Waveform	
TP202	Column Y sweep signal	<ul style="list-style-type: none"> Mode: NORMAL, OBLIQUE  <p>Amplitude changes by about 1 digit throughout magnification range, and is variable with VR213 (with STAGE at LOWER) or VR216 (with STAGE at UPPER)</p>	<ul style="list-style-type: none"> Auto focus 
			<ul style="list-style-type: none"> Mode: W. FORM, FOCUS SEARCH 

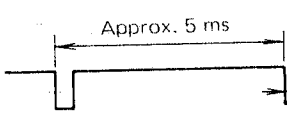
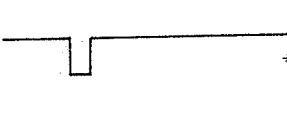
(5) Voltage and waveform at each point of video control unit

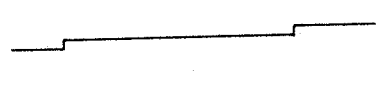
Check Point	Item	Voltage and Waveform																
TP301	Fixed brightness signal	Signal ($\overline{\text{SFVDO}}$) for determining a fixed CRT brightness without changing it according to image signal. Valid only when CFVDO signal is "LOW". (Setting is made by 8-bit data given to DAC IC F2.) <table border="1" data-bbox="662 936 1052 1182"> <thead> <tr> <th>Mode</th> <th>Voltage</th> </tr> </thead> <tbody> <tr> <td>Normal</td> <td>Non Fixed</td> </tr> <tr> <td>Data List</td> <td>0 V</td> </tr> <tr> <td>W. Form</td> <td>+2.4 V</td> </tr> <tr> <td>Oblique</td> <td>+2.4 V</td> </tr> <tr> <td>Oblique, Photo</td> <td>+4.3 V</td> </tr> </tbody> </table>		Mode	Voltage	Normal	Non Fixed	Data List	0 V	W. Form	+2.4 V	Oblique	+2.4 V	Oblique, Photo	+4.3 V			
Mode	Voltage																	
Normal	Non Fixed																	
Data List	0 V																	
W. Form	+2.4 V																	
Oblique	+2.4 V																	
Oblique, Photo	+4.3 V																	
TP307	ABC operation timing signal	<ul style="list-style-type: none"> In ABC IC B9 - ⑨ pin (Y-BI) 	 <p>Approx 1 ms</p>															
Relays RY1, RY2	ABC changeover relays	<table border="1" data-bbox="597 1528 1182 1686"> <thead> <tr> <th>AUTO-MAN-INV SW</th> <th>ABC</th> <th>RY1</th> <th>RY2</th> </tr> </thead> <tbody> <tr> <td rowspan="2">AUTO</td> <td>ON</td> <td>ON</td> <td>ON</td> </tr> <tr> <td>OFF</td> <td>OFF</td> <td>ON</td> </tr> <tr> <td>MAN or INV</td> <td></td> <td>OFF</td> <td>OFF</td> </tr> </tbody> </table>		AUTO-MAN-INV SW	ABC	RY1	RY2	AUTO	ON	ON	ON	OFF	OFF	ON	MAN or INV		OFF	OFF
AUTO-MAN-INV SW	ABC	RY1	RY2															
AUTO	ON	ON	ON															
	OFF	OFF	ON															
MAN or INV		OFF	OFF															

Check Point	Item	Voltage and Waveform
AFC-related parts	Signal detection for auto focus	• Under rough focus and moderate contrast
		IC F11- ⑦ pin  (Video signal)
		IC E11- ① pin  Wider at higher contrast
		• In AFC (COARSE)
		IC B7- ④ pin  Approx. 5 ms Approx. 10 µs
		IC B7- ⑫ pin  Approx. 50 µs
		IC E10- ⑦ pin  Wider at higher contrast ~ 0 V
TP309  ← Equal to maximum level at IC E10-⑦ pin		
TP306  ← Almost equal to voltage at TP309		

(6) Voltage and waveform at each point of lens control unit.

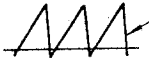
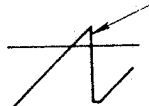
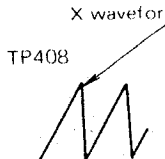
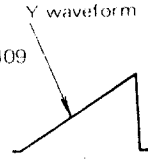
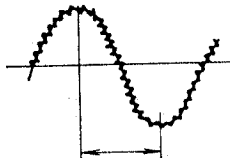
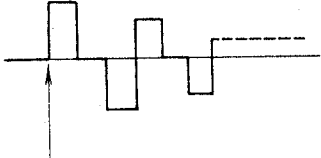
Check Point	Item	Voltage and Waveform											
TP401 TP402	Reference voltage for lens system	Reference voltage corrected for accelerating voltage $V = 9.8 \sqrt{\frac{HV}{30}} \quad (\text{Example})$ <table border="1" style="display: inline-table; vertical-align: middle;"> <thead> <tr> <th>HV</th> <th>V</th> </tr> </thead> <tbody> <tr> <td>30 kV</td> <td>9.8 V</td> </tr> <tr> <td>20</td> <td>8.0</td> </tr> <tr> <td>10</td> <td>5.7</td> </tr> <tr> <td>1</td> <td>1.8</td> </tr> </tbody> </table> <p>TP401 is at negative level, and TP402 at positive level.</p>		HV	V	30 kV	9.8 V	20	8.0	10	5.7	1	1.8
HV	V												
30 kV	9.8 V												
20	8.0												
10	5.7												
1	1.8												
TP403	Reference voltage for objective lens	<ul style="list-style-type: none"> Changes according to selection of accelerating voltage, WD setting, focus coarse and STAGE switch 											
TP404 TP405	Reference voltage for condenser lens	TP404 and TP405 voltages variable from $-3 \sim -9.8$ V with 2CON switch and 1CON variable resistor respectively (at HV 30 kV)											
TP406	Reference voltage for stigmator (X)	<ul style="list-style-type: none"> In other than stigmator monitor mode Variable by ± 10 V with STIGMA (X) VR (at HV 30 kV)	<ul style="list-style-type: none"> In stigmator monitor mode  <p>X waveform Level variable with STIGMA (X) VR</p>										
TP407	Reference voltage for stigmator (Y)	<ul style="list-style-type: none"> In other than stigmator monitor mode Variable by ± 10 V with STIGMA (Y) VR (at HV 30 kV)	 <p>Y waveform</p>										
TP408 TP409	Gun alignment for filament image	<ul style="list-style-type: none"> In other than filament image mode Fixed at 0 V	<ul style="list-style-type: none"> In filament image mode   <p>Approx. 17 Vp-p (30 kV) Approx. 20 Vp-p (30 kV) Amplitude proportional to square rooted HV</p>										
TP410	Dynamic focus reference voltage (for auto focus)	<ul style="list-style-type: none"> AFC alignment  <p>Approx. 0.3 s</p> <p>Maximum amplitude 17 Vp-p (varies with HV and magnification)</p>	<ul style="list-style-type: none"> During auto focus  <p>AFC start</p>										

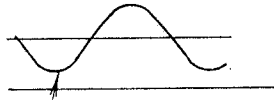
Check Point	Item	Voltage and Waveform	
TP411 TP412	Image shift	Variable by ± 5 V with IMAGE SHIFT (X), (Y) controls (at HV 30 kV)	<ul style="list-style-type: none"> • AFC ALIGN  <p data-bbox="1076 443 1341 527">Amplitude variable with AFC ALIGN (X) or (Y) VR (TP411 corresponds to (X), and TP412 to (Y).)</p>

Note: The X and Y sweep waveforms which are superimposed at the TPs 406 to 409 are adjusted for amplitude by the D/A converter of IC C5 and C4, and are turned on/off by the switch IC E3.

4-4 Adjustment of CRT

4-4-1 Viewing CRT

- (1) Set the scan speed **REDUCE**, and adjust the VRs 203 and 206 so that the waveform at the TPs 201 (X) and 204 (Y) of the ANLG circuit board appears with the center at 0 V. Then, adjust the centering magnet of CRT so as to locate the raster at the center of CRT. (This adjustment is required only when replacing the CRT with a new one. Be careful not to cause burning of CRT screen due to too intense brightness.)
- (2) Adjust amplitude and location.

Direction	Amplitude	Location	ANLG circuit board
X	170 mm (VR201)	Center (VR203)	
Y	206 mm (VR207)	Center (VR206)	

4-4-2 Photographing CRT

- (1) Procedure for displaying raster on photo CRT.
 - Set MAG PRESET 1 to 98.
 - Set DATA NO. to 420000.
 - Enter **CALL**, **9** and **5** from the keyboard, and raster will appear on the photo CRT (with character frame).
- (2) Focus of CRT
 - For the standard CRT, adjust VR3 on the **VA** circuit board.
 - For the high resolution CRT, adjust VR15 on the circuit board in photo CRT unit.

(3) Amplitude and location

Direction	Amplitude	Location	On ANLG circuit board
X	107 mm (VR202)	Center (VR204)	
Y	130 mm (VR209)	Center (VR208)	

(Adjusting the VR208 is allowed if a photographed image is deviated in the Y direction.)

(4) Pincushion distortion

If adjustment is required, adjust the cylindrical magnets at the four corners of the deflection coil by turning.

4-4-3 Character Display Location

The X-directional width of characters needs to be adjusted so that the micron marker has a length of 30 mm on a photograph, and the location so that data on a photograph are centered in the horizontal direction. If deviated from the center, proceed as follows.

- (1) Adjust the character width and location accurately on a photograph at the photo speed **2**.
- (2) At the photo speed **3**, adjust the character width so that display appears at the same location as at **2** on the viewing CRT.
- (3) At each scan speed in viewing mode, make adjustment so that display appears at the same location as at the scan speed **4** (this is the same condition as the photo speed **2** which has already been adjusted in step (1) above).
- (4) If the Y-directional location is deviated, Y scan speed or CRT deflection width may be considered abnormal.
(Characters are located according to the number of scan lines counted from the start of Y scan.)
- (5) For adjustment, use the VRs on the **DG** circuit board.

Scan Speed	Width	Position
RAPID	VR7	VR9
1, 2	VR8	} VR10
3	VR5	
4	(VR6)	
PHOTO 1	(VR5)	
PHOTO 2	VR6	
PHOTO 3	VR3	

4-4-4 Rapid Scan

The scan speed **RAPID** differs from other scan speeds in the following; (1) CRT is deflected by the switching deflection circuit consisting mainly of the Q10 (FET for switching) on the **DEF** circuit board, and (2) the X-sweep waveform for deflecting the column lenses is generated in an exclusive circuit (on the **RSG** circuit board).

For waveform, etc., refer to the simplified circuit diagrams (Figs 4-11 and 4-13).

4-5 Adjustment of Magnification

Since this instrument utilizes a working distance down to -3 mm, the deflecting point needs to be adjusted accurately. Therefore, the instrument has a function for adjusting the deflecting point. Magnification varies at different deflecting points, so adjustment of the deflecting point must be made prior to that of magnification. (Avoid shifting the deflecting point usually, since it results in change of magnification.)

4-5-1 Adjustment of Deflecting Point

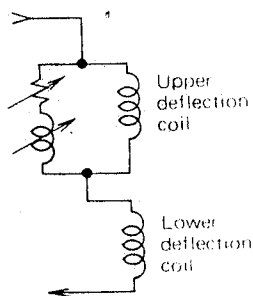

The deflecting point can be adjusted by changing the ratio of the currents flowing through the upper and lower deflection coils shown at the left. The variable choke coil is used for correcting the current ratio in the rapid scan mode.

- (1) With the working distance at -2 mm, and the STAGE/SED switches at UPPER, set the lowest magnification by pressing the MAGNIFICATION PRESET LOW switch with an accelerating voltage of 25 kV. Adjust the VRs 1 and 2 on the power circuit board (CDTB circuit board) of the microscope column so as to minimize peripheral blur at the scan speed **1**. (For S-2500C, make adjustment with WD = 15 mm.)
- (2) Adjust the choke coil at the scan speed **RAPID** the same as in (1) above.

4-5-2 Adjustment of Relative Magnification Value after Changing Working Distance

- (1) Set both STAGE and SED switches to LOWER. Measure image magnification under the same magnification display at working distances of 5 and 35 mm. Set the switch 3 on the DG circuit board so as to minimize the difference between the display and measured magnifications.
- (2) Set both STAGE and SED switches to UPPER. At working distances of -3 and $+1$ mm, adjust the switch 2 on the DG circuit board in the same manner as in (1). (Except for S-2500C)

4-5-3 Adjustment of Orthogonality

Adjust the VR212 on the ANLG circuit board so as to obtain an orthogonality accuracy of ± 0.5 degree or less.

4-5-4 Adjustment of Magnification (Absolute Value)

Adjust the absolute magnification on the photo CRT under the following conditions. For setting the working distance, make entry with the numerical keys and match the Z-control knob setting of the specimen stage with the entry.

Conditions: HV 20 kV
Specimen 1,000-mesh grid
Magnification 1000X

- At working distance 15 mm (with STAGE LOWER), adjust the X and Y magnifications with the ANLG circuit board VRs 214 and 213 respectively.
- At working distance -2 mm (with STAGE UPPER), adjust the X and Y magnifications with the VRs 215 and 216. (Except for S-2500C)

4-5-5 Adjustment of Magnification in Rapid Scan

(1) Adjustment of raster amplitude in rapid scan

Adjust the VR211 on the ANLG circuit board so as to match the right end of raster with that of CRT. (The left side of the raster extends beyond CRT.)

(2) Matching magnification and image location between rapid and slow scan (in X direction only)

Adjust the VRs 1 (magnification) and 2 (location) so as to obtain coincidence between scan speed **1** and **RAPID**.

4-6 Description of CRT and Column Deflection Circuits

Figs. 4-11 and 4-13 show simplified circuit diagrams of the CRT deflection circuit, column deflection circuit and that in the rapid scan mode.

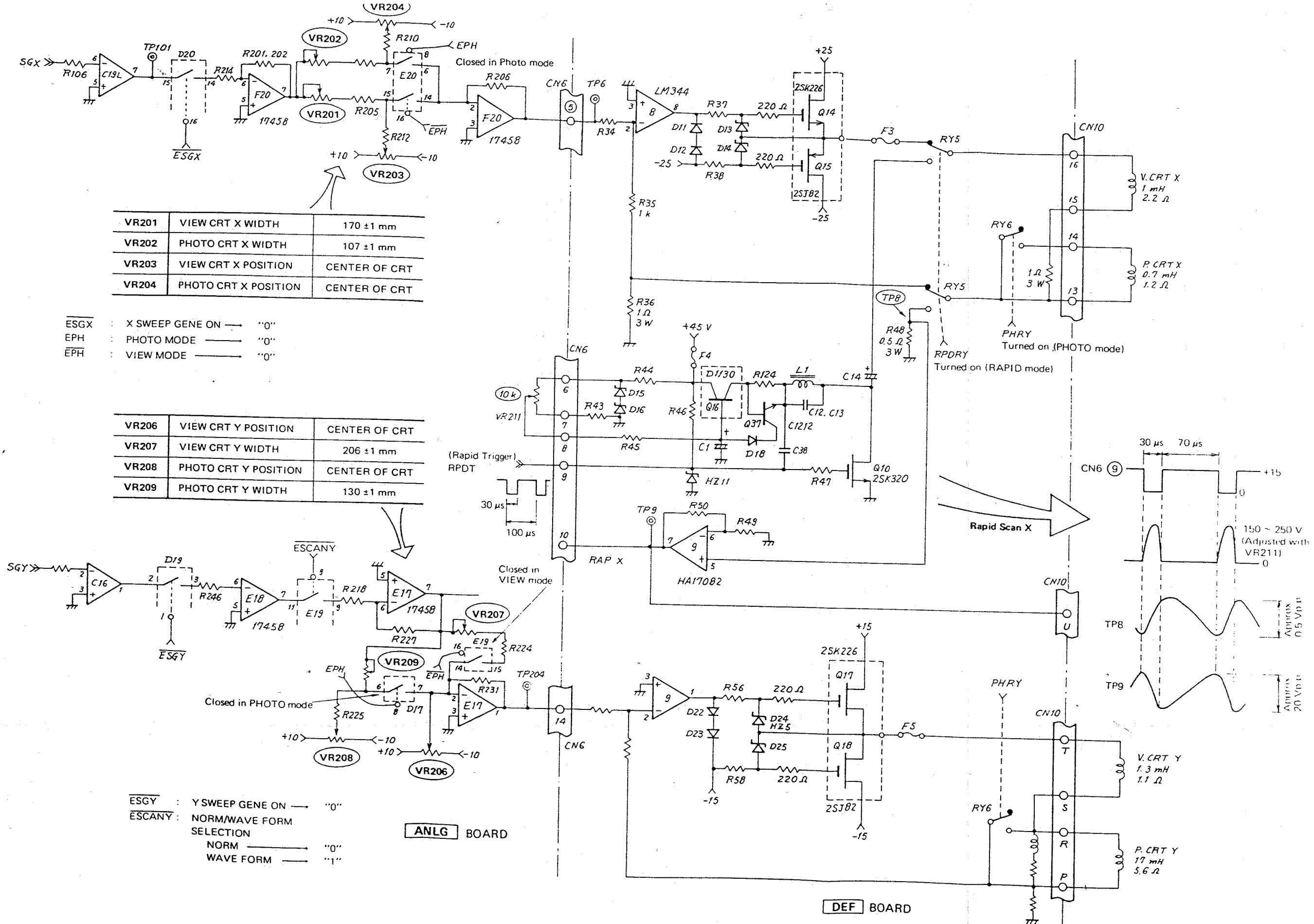

VR201	VIEW CRT X WIDTH	170 ± 1 mm
VR202	PHOTO CRT X WIDTH	107 ± 1 mm
VR203	VIEW CRT X POSITION	CENTER OF CRT
VR204	PHOTO CRT X POSITION	CENTER OF CRT

ESGX : X SWEEP GENE ON → "0"
 EPH : PHOTO MODE → "0"
 EPH : VIEW MODE → "0"

VR206	VIEW CRT Y POSITION	CENTER OF CRT
VR207	VIEW CRT Y WIDTH	206 ± 1 mm
VR208	PHOTO CRT Y POSITION	CENTER OF CRT
VR209	PHOTO CRT Y WIDTH	130 ± 1 mm

ESGY : Y SWEEP GENE ON → "0"
 ESCANY : NORM/WAVE FORM SELECTION
 NORM → "0"
 WAVE FORM → "1"

ANLG BOARD

DEF BOARD

Fig. 4-11 Simplified Circuit Diagram of CRT Deflection Circuit

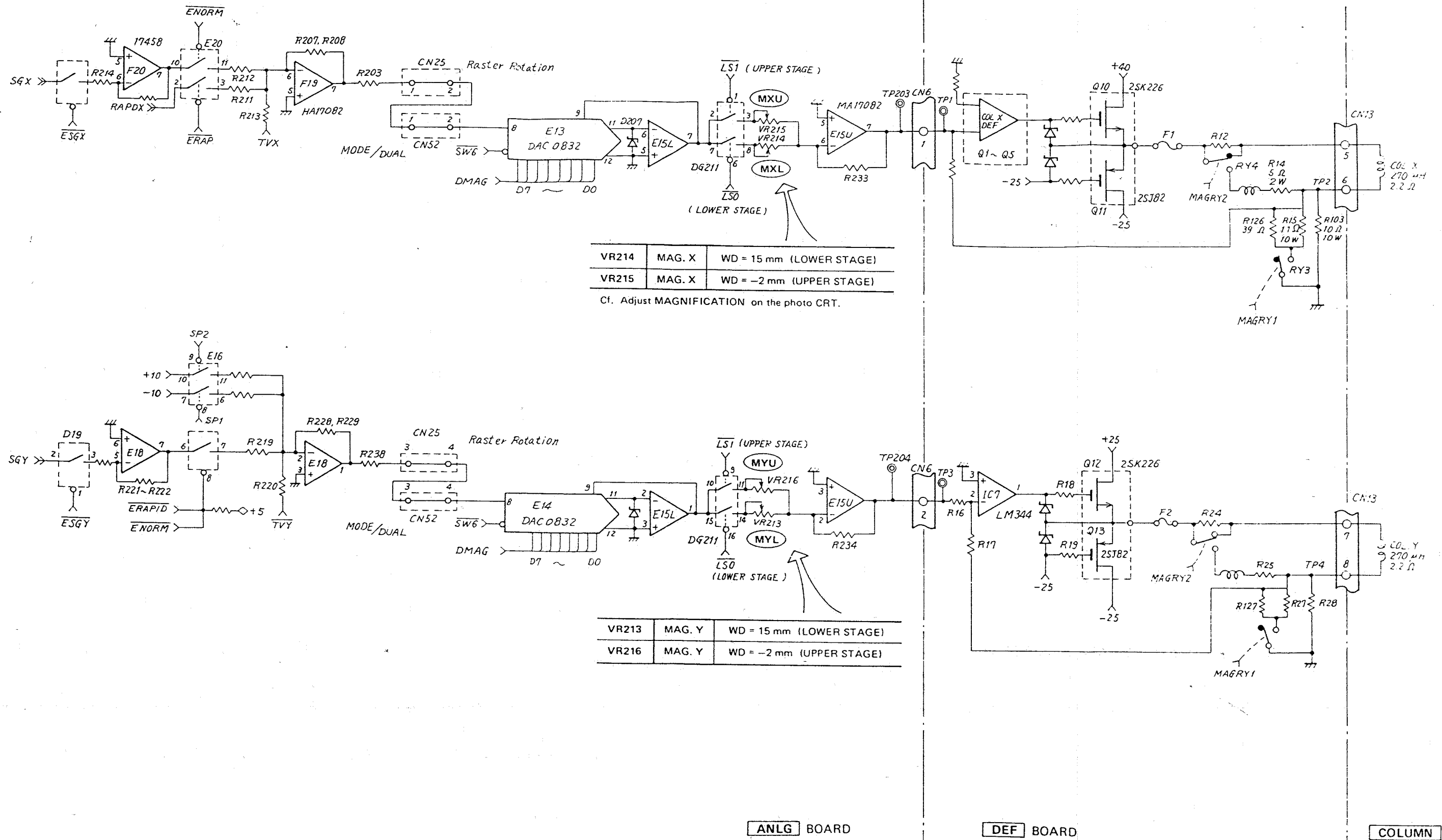

Fig. 4-12 Simplified Circuit Diagram of Column Deflection Circuit

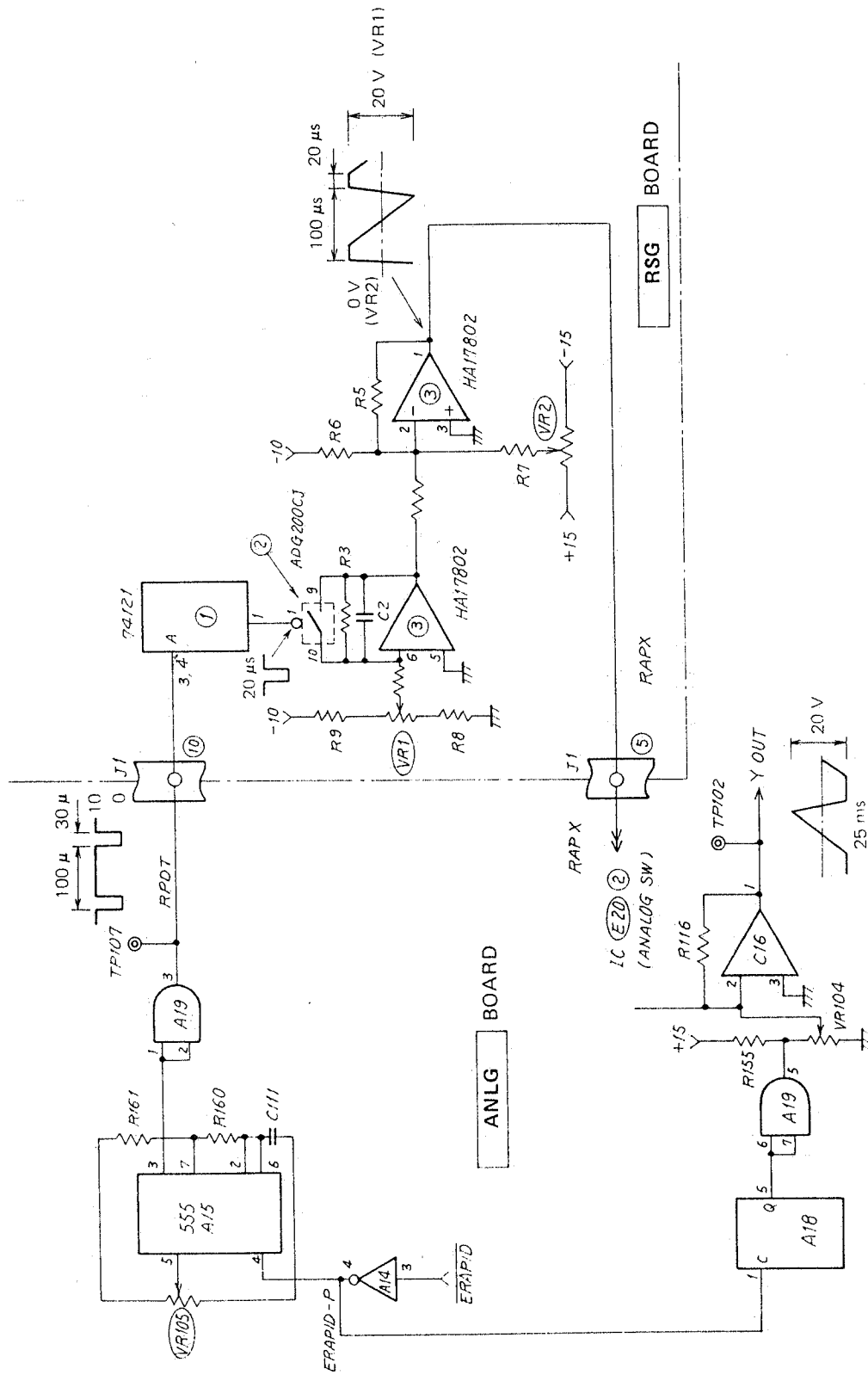

Fig. 4-13 Column Deflection Circuit in Rapid Scan Mode

4-7 Adjustment of Lens Circuits

4-7-1 Objective Lens Circuit

(1) Adjustment of FOCUS COARSE rotary encoder detector

Adjust the VRs 1 and 2 on the DG circuit board so that the waveform shown below appears at the IC **(F14)** on the circuit board when turning the FOCUS COARSE knob on the operation panel.

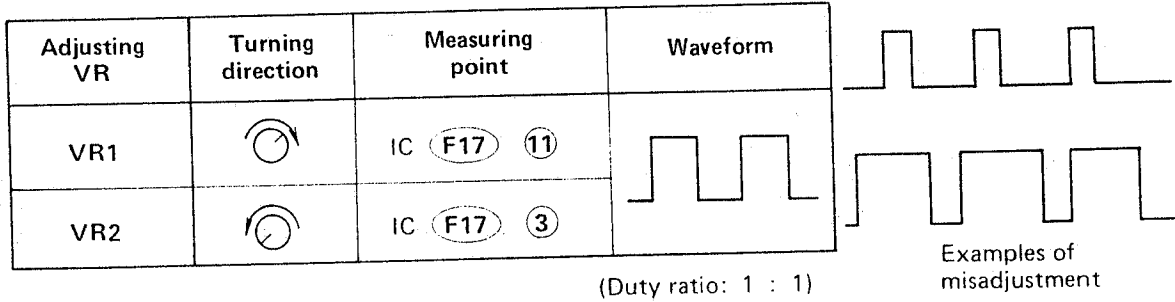

(2) Confirmation of reference voltages

The reference voltages are given as follows linked with HV setting.

$$-9.8\sqrt{\frac{HV}{30}} \text{ at TP401}$$

$$+9.8\sqrt{\frac{HV}{30}} \text{ at TP402}$$

(3) Adjustment of focus current

This instrument utilizes a wide working distance range of -3 to 60 mm. So, the range is divided into 2 with reference to a working distance of 0 for adjusting the focus current. Each of the divided ranges is selectable by setting the STAGE switch to UPPER or LOWER. Focus current is adjusted independently by 2 trimmers for each of the UPPER and LOWER distances (4 trimmers provided in total). Shown below is the relationship between the working distance and focus current. (Except for S-2500C)

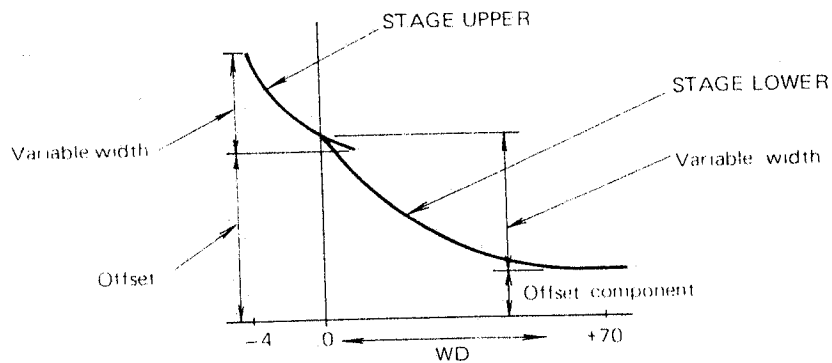

The variable width with the FOCUS COARSE knob and the offset component with the knob at minimum are adjustable for both STAGE LOWER and UPPER settings. The offset component is adjusted at longer working distance, and the variable width at shorter working distance.

(Adjusting procedure) (Set HV at 20 kV, and use the specimen holder for adjusting focus current.)

(1) STAGE LOWER

- (a) Set the STAGE switch to LOWER.
- (b) Enter $WD = 35$ (mm) with the numerical keys, and adjust the specimen height to 35 mm also. Adjust the VR401 on the ANLG circuit board to focus an image. (Although the FOCUS COARSE knob can be set at any position, it must not be moved until the adjustment is completed.)
- (c) Enter $WD = 5$ (mm) with the numerical keys, and adjust the specimen height to 5 mm also. Adjust the VR403 so as to obtain a just-focus.
- (d) Repeat steps (b) and (c) until the image is brought into focus at both working distances 35 and 5 mm.

(2) STAGE UPPER

- (a) Set the STAGE and SED switches to UPPER.
- (b) Enter $WD = 0$ with the numerical key, and set the specimen height to 0 mm also. Adjust the VR402 so as to obtain a just-focus.
- (c) Enter $WD = -3$ (mm) with the numerical keys, and set the specimen height to -3 mm also. Adjust the VR404 so as to obtain a just-focus.
- (d) Repeat steps (b) and (c) until the image is brought into focus at both working distances 0 and -3 mm.

Note: Focus current level must be adjusted accurately since it is utilized for calculating magnification.

For S-2500C, carry out steps (b) thru (d) only.

Fig. 4-14 shows a simplified circuit diagram of the objective lens circuit.

4-7-2 Condenser Lens Circuit

In this instrument, the first and second condenser lens currents are variable independent of each other. The condenser lens circuit does not require adjustment in particular, though the reference voltage changes linked with accelerating voltage.

4-8 Stigmator Circuit

The reference voltage of this circuit is ± 10 V. The voltage at the TPs 406 and 407 are varied from -10 to $+10$ V by the STIGMA X and Y knobs on the operation panel. In this instrument, the reference voltage of the stigmator circuit is not linked with accelerating voltage. The circuit adjusts only an image escape occurring when correcting astigmatism. Adjusting procedure is described below.

< Stigmator Alignment Adjustment >

Adjust STIG ALIGN VR equipped inside the blind panel so that an image will not move with item 2 STIGMA ALIGNMENT selected on the menu screen 9 SYSTEM CHECK.

- STIGMA X adjustment
 - Horizontal movement : XX VR
 - Vertical movement : XY VR
- STIGMA Y adjustment
 - Horizontal movement : YX VR
 - Vertical movement : YY VR

Make adjustment so that an image will be stable at a magnification as high as possible.

(Stigmator monitor)

When the STIGMA MONITOR switch is turned on, X and Y sweep waveforms are superimposed at the TPs 406 and 407 according to selected accelerating voltage and magnification.

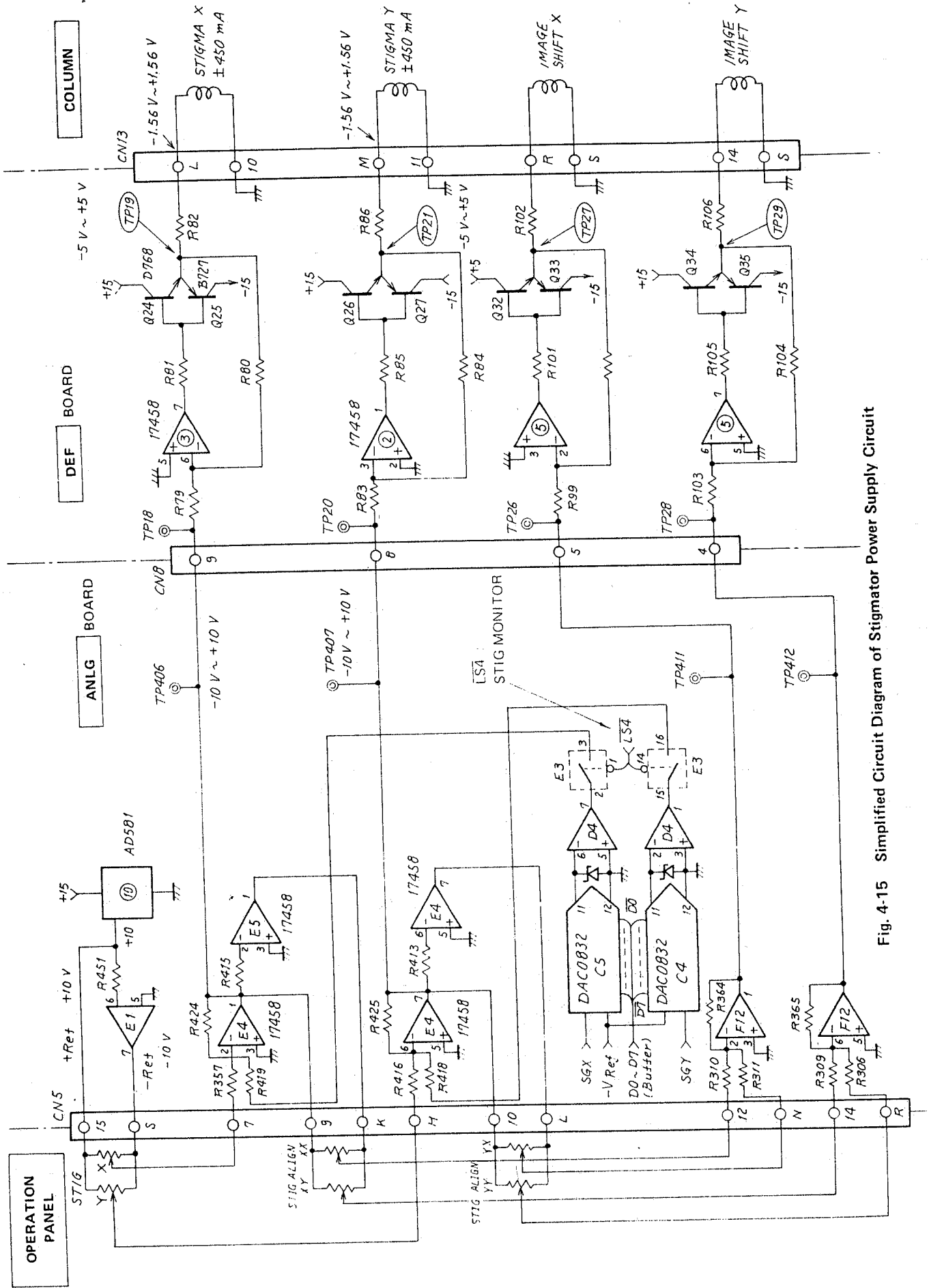
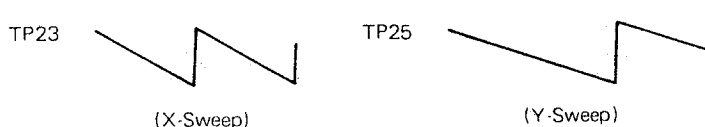

Fig. 4-15 Simplified Circuit Diagram of Stigmator Power Supply Circuit



4-9 Voltage and Waveform at Each Point of DEF Circuit Board

Check Point	Item	Voltage and Waveform
TP2	COL X deflection output	$-0.12 \times$ (voltage at TP1)
TP4	COL Y deflection output	$-0.12 \times$ (voltage at TP3)
Rapid scan-related points		<p>D17 CATHODE (RPD TRG) — Approx. 10 V</p> <p>Q10 DRAIN (D19 CATHODE) — Approx. 0.5 Vp-p</p> <p>TP8 — Approx. 20 Vp-p</p> <p>TP9 — Approx. 20 Vp-p</p> <p>0</p> <p>100 ~ 250 V</p>
TP7	CRT X deflection output	$-0.12 \times$ (voltage at TP6)
TP11	CRT Y deflection output	$-0.18 \times$ (voltage at TP10)
RY5	Rapid/slow changeover relay	SCAN SPEED RAPID → ON SLOW → OFF
RY6	View/photo changeover relay	VIEW → ON PHOTO → OFF
TP13	OBJ lens power output	$-0.36 \times$ (voltage at TP12)
TP15	2nd CON lens power output	$-0.24 \times$ (voltage at TP14)
TP31	1st CON lens power output	$-0.24 \times$ (voltage at TP30)
TP17	Dynamic focus coil power output	Output appears during AFC alignment only

Check Point	Item	Voltage and Waveform
TPs 19/21	Stigma (X, Y) output	-1 x (voltage at TPs 18, 20)
TPs 23/25	Filament image output	Filament image 
TPs 27/29	Image shift (X, Y) output	-1 x (voltage at TPs 26, 28)

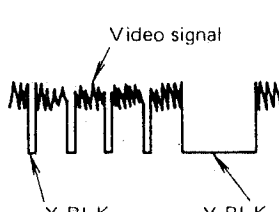
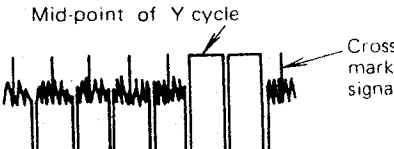
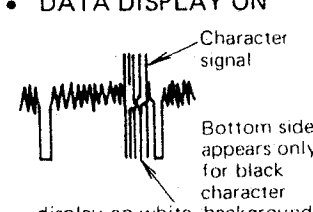
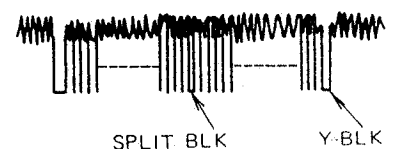
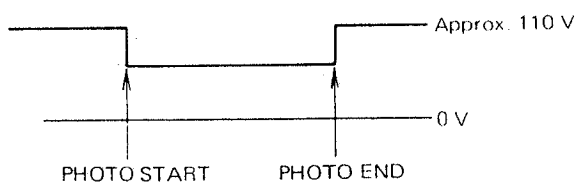
4-10 Voltage and Waveform at Each Point of VA Circuit Board

Check Point	Item	Voltage and Waveform	
TP1	Video amp out.	<ul style="list-style-type: none"> • About 5 Vp-p under normal contrast • DC level increases by about +2 V and amplitude widens slightly at scan speed RAPID • Noise component is reduced at lower scan speed 	
TP2	View CRT grid signal	<ul style="list-style-type: none"> • Mode: NORMAL 	<ul style="list-style-type: none"> • Mode: STIGMA MONITOR 
		<ul style="list-style-type: none"> • DATA DISPLAY ON 	<ul style="list-style-type: none"> • Mode: SPLIT 
TP3	Photo CRT grid signal	Same as in TP2	
TP5	Photo CRT cathode signal		

Check Point	Item	Voltage and Waveform
CN29 CN30		CN29 pin ⑪ About +415 V pin ⑩ About 0 V CN30 pin ⑲ 610 V pin ⑱ 0 ~ +610 V (variable with VR3)
		
		
TP6		<ul style="list-style-type: none"> • Normally about 2 V • About 0.5 V when spot killer activated (in SPOT mode with Model S-5704) Spot killer is activated when this point becomes low level.

4-11 High Voltage Circuit

(1) Reference voltage (HV CONT circuit board TP1)

The reference voltage is determined by the DA converter (DAC0831) according to the HV control signals D0 to D4 sent from the CPU. Its maximum value is $-9.41 \text{ V}/30 \text{ kV}$ (-0.314 V/kV).

(2) Adjustment of oscillating frequency (HV CONT circuit board TP2)

The VR2 on the HV CONT circuit board adjusts the oscillating frequency at the TP2.

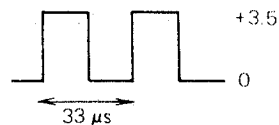

(3) Setting of high voltage (HV CONT circuit board TP3)

High voltage is set by the trimmer VR1 in the HV CONT circuit board. A voltage of 18 V appears at the TP3 when an accelerating voltage of 30 kV is applied.

(4) Bias voltage (HV CONT circuit board TP4)

The voltage at the TP4 is variable from 0 to +25 V by the BIAS knob on the operation panel.

(5) Filament voltage (HV CONT circuit board TP5)

The voltage at the TP5 is variable from 0 to +23 V by the FILAMENT knob on the operation panel.

(6) Detection of emission current (HV CONT circuit board TP6)

Emission current is detected in the IC ⑤ (HA17458) on the HV CONT circuit board. A voltage of $-10 \text{ mV}/\mu\text{A}$ appears at the TP6. The emission current meter has a full scale of 300 μA .

(7) Overcurrent limiter

If an excessively large emission current is flowed, it is detected by the comparator IC ⑥ (LM311) and the +36 V power supply is turned off.

The IC ⑥ is activated when TP6 voltage becomes $-3.5 \text{ V}/350 \mu\text{A}$.

(8) Adjustment of preset filament current

The VR3 adjusts the maximum filament current.

(a) For LaB₆ gun, a current value specified for the tip used is set with the **FILAMENT** knob at maximum.

(b) For W-hairpin gun, emission current is set so as to saturate with the **FILAMENT** knob at about 2 to 3 o'clock position.

Fig. 4-16 shows a simplified circuit diagram of the high voltage circuit.

4-12 Table of Connector Signals

VA circuit board

CN No.	Pin No.	Signal Name	Remarks	I/O	Destination
26	1	+15 V output	Signal from preamp	O	SE detector
	2	GND		O	
	3	SE IN		I	
	4	—			
	5	-15 V output		O	
	6	Preamp bias		O	
	7	—			
	8	—			
	9	—			
	10	(PM HV output)		O	
	11	GND		O	
27	1	F1	} Filter selecting signal for Model S-6540	O	(Option) Model S-6540
	2	F2		O	
	3	F3		O	
	4	—			
	5	GND			
28	1	Video output	After selecting SE/EXT/X-RAY	O	(Option) TV & external output
	2	Y-BL	Y-blanking output	O	
	3	BLK	(X + Y) blanking output	O	
	4	EXT BU	External signal for brightening CRT (for character data, etc.)	I	
	5	EXT BL	External signal for blanking CRT	I	
	6	Px	X scan signal } (changeable by R51/53)	O	
	7	Py	Y scan signal }	O	
	8	TV VIDEO	Video signal output to TV (preamp + emitter follower)	O	
	9	} GND			
	10				
	11				
30	1	P DEF X -	} Photo CRT deflection coil	O	Photo CRT
	2	P DEF X +		O	
	3	P DEF Y +		O	
	4	P DEF Y -		O	
	5	H	} CRT heater	O	
	6	H		O	
	7	G1		O	
	8	K	G1 (video signal) K (cathode bias)	O	
	9	—		O	

CN No.	Pin No.	Signal Name	Remarks	I/O	Destination
30	10	P _X	} X, Y signals for Model S-4007	O	Photo CRT
	11	P _Y		O	
	12	—			
	13	—			
	14	—			
	15	—			
	16	—			
	17	—			
	18	G4		O	
19	G2		O		
10	1	—	100 V input (for cathode bias)	I	DEF
	A	+100 V			
	2	—			
	B	—			
	3				
	C				
	4	+15 V*	+15 V input for 600 V PM HV power supply	I	
	D	+15 V	+15 V input for general use	I	
	5	GND*	GND for 600 V PM HV power supply	I	
	E	GND	General grounding	I	
	6	} -15 V		I	
	F				
	7	+	} Vacuum-link contact signal (contact closes under high vacuum)	I	
	H	0			
	8	} -15 V		I	
	J				
	9	} +15 V	Power supply for S-4007, relayed to CN30	I	
K					
10	} GND		I		
L					
11	} +5 V	+5 V input	I		
M					
12	} GND	0	I		
N					
13	P DEF X -	} Photo CRT deflection current, relayed to CN30	I		
P	P DEF Y -				
14	P DEF X +				
R	P DEF Y +				
15	V DEF X -	} CRT deflection current, relayed to CN29	I		
S	V DEF Y -				
16	V DEF X +				
T	V DEF Y +				
17	SLOW X	} Scan (CRT) signal for spot killer	I		
U	RAPID X				
29	1	V DEF X +	} Viewing CRT deflection current output	O	Viewing CRT
	2	V DEF X -			
	3	V DEF Y +			
	4	V DEF Y -			
	5	H	} CRT heater	O	
	6	H			

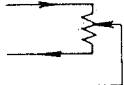
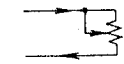
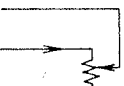
CN No.	Pin No.	Signal Name	Remarks	I/O	Destination	
29	7	G1	Video signal	O	Viewing CRT	
	8	K	Cathode bias	O		
	9	—				
	10	G4		O		
	11	G2		O		
11	1		 Photo contrast VR		Panel	
	2					
	3					
	4	—				
	5	—				
	6		 CRT BRIGHT			
	7					
	8	—				
	9		 Photo CRT BRIGHT			
	10					
	11					
7	1	VDOA	Video signal (for ABC function)	O	ANLG	
	A	VDO	Video signal for Y modulation	O		
	2	PSIG	Preamp output (video signal for AFC function)	O		
	B	ANALOG GND				
	J					
	3		BIAS	Preamp bias (from ANLG circuit board)		I
	4		+5 V reference	Output		O
	5	GND	Input	O		
	6	PM HV reference		I		
	7	SFVDO	Fixed brightness voltage	I		
	8	Px	} X, Y signal inputs for S-4007	I		
	9	Py		I		
	K	DIGITAL GND				
	J					
	S					
	10	BLK	(X + Y) blanking input	I		
	11	Y-BL	Y blanking input	I		
	12	B \bar{U}	Signal input for brightening cross mark	I		
	13	SPBL	Central blanking input in split screen mode	I		
	14	DATA	Signal input for brightening character	I		
15	DDBL	Signal input for data display on white background	I			
16	SS1	} Signal selection input	I			
T	SS2		I			
17	SS3		I			
U	MSK	X-RAY	I			
		Signal input for brightening frame in dual mag mode	I			

(Continued)

CN No.	Pin No.	Signal Name	Remarks	I/O	Destination
7	18	$\overline{F1}$	Filter selection signal		ANLG
	V	$\overline{F2}$			
	19	$\overline{F3}$			
	W	$\overline{F4}$			
	20	$\overline{GM1}$	Gamma control selection signal		
	X	$\overline{GM2}$			
	21	POL	Polarity inversion signal		
	Y	\overline{CFVDO}	Signal for changing CRT brightness signal to fixed brightness		
	22	$\overline{FS1}$	Signal for selecting brightness of photo CRT according to sensitivity of film		
	Z	$\overline{FS2}$			
	23	$\overline{FS3}$			
	A*	$\overline{FS4}$			
	24	\overline{RAPID}	Signal for enhancing contrast and brightness in RAPID scan		
	B*	\overline{SPKDIS}	Signal for inactivating spot killer		
	25	\overline{EPMH}	PM HV ON signal		
C*	\overline{EPCRT}	Signal for displaying raster on photo CRT			

DG circuit board

CN No.	Pin No.	Signal Name	Remarks	I/O	Destination		
3	1~3	} GND	Data bus	O	ANLG		
	A~C						
	4					$\overline{D7}$	
	D	$\overline{D6}$					
	5	$\overline{D5}$					
	E	$\overline{D4}$					
	6	$\overline{D3}$					
	F	$\overline{D2}$					
	7	$\overline{D1}$					
	H	$\overline{D0}$					
	8	$\overline{AD0}$				} Lower address 3 bits	
	J	$\overline{AD1}$					
	9	$\overline{AD2}$					
	K						
	10	\overline{ENA}				CPU timing signal	O
	L	$\overline{DVN5}$				Upper address (\$8028 ~ 802F)	O
	11	$\overline{DVN4}$				Upper address (\$8020 ~ 8027)	O
	M	$\overline{INT1}$				Interrupt input	I
	12	$\overline{DVN3}$				Upper address (\$8018 ~ 801F)	O
N	$\overline{INT3}$	Interrupt input	I				
13	$\overline{DVN6}$	Upper address (\$8030 ~ 8037)	O				
P	\overline{DATA}	Character signal	I				
14	\overline{DDBL}	Signal for character display on white background	I				
R	$\overline{INT7}$	Interrupt input	I				

CN No.	Pin No.	Signal Name	Remarks	I/O	Destination		
3	15	$\overline{X-BI}$	X blanking signal	I	ANLG		
	S	$\overline{INT5}$	Interrupt input	I			
	16	$\overline{Y-BI}$	Y blanking signal	I			
	T	$\overline{INT6}$	Interrupt input	I			
	17	SGX	X scan signal	I			
	U						
	18						
	V						
	19	-15 V	} Power supply for data display circuit	I			
	W	0		I			
	20			I			
	X			I			
	21	+15 V		I			
	Y						
22							
Z							
23~25 A'~C'	} +5 V		O O				
2	1	High	} stage } gamma control	} Contact signal of selector switch (functions at left available at voltage level 0)	Panel		
	2	Low					
	3	2					
	4	OFF					
	5	Upper	} post HV				
	6	Lower					
	7	Auto	} signal				
	8	INV					
	D~J	GND	} MAG SW				
	K	UP					
	L	DWN					
	9	E1					
	10	E2	} Rotary encoder output				
A							
		} +5 V	} Rotary encoder (FOCUS COARSE) power supply				
C							
1	N	RL7	} Return signal line of matrix for reading panel switch RL: Return Line	I			
	13	RL6					
	P	RL5					
	14	RL4					
	R	RL3					
	15	RL2					
	S	RL1					
	16	RL0					
	21	S0				} Scan signal line of above matrix S: Scan line	O
	20	S1					O
19	S2	O					
18	S3	O					
17	S4		O				

CN No.	Pin No.	Signal Name	Remarks	I/O	Destination			
1	22	D0	2nd and 1st digits of HV 1st decimal digit of HV, 3rd digit of MAG 2nd and 1st decimal digits of MAG Decimal point of 7 segments, etc.	*1	O			
	Z	D1						
	23	D2						
	A'	D3						
	24	D4						
	B'	D5						
	25	D6						
	C'	D7						
	7	g1						
	H	f1						
	D	e1						
	5	d1					Segment line of 7-segment LED for 2nd/1st decimal digits of HV and 2nd digit of MAG (current sink side)	I
E	c1							
6	b1							
F	a1							
C	g2							
4	f2							
1	e2							
A	d2							
2	c2							
B	b2							
3	a2							
J	L7	Segment line of 7-segment LED for 1st digit of HV and 3rd/1st digits of MAG (current sink side)	I					
9	L6							
K	L5							
10	L4							
L	L3							
11	L2							
M	L1							
12	L0							
					Lighting line of individual LED (current sink side)	I		
4	3	(D0)	HV setting data (0 ~ 31 kV)	O				HVC
	4	(D1)						
	5	(D2)						
	6	(D3)						
	7	(D4)						
	8	(D5)						
	9	POST L			HV digit selecting data (1: 0 ~ 31 kV, 0: 0 ~ 3.1 kV)	O		
	10	(D7)						
	C	POST U						
	1	HV READY				O		
	A							
	2	OVERCURR. LIMITER				O		
B								
D~L	GND	OCL activated at "1"	O					



*1: Digit scan line for LED display (current source side)



CN No.	Pin No.	Signal Name	Remarks	I/O	Destination
70 74	1	} +5 V.	Bus for external connection of CPU		
	A~D				
	2	$\overline{D0}$			
	3	$\overline{D1}$			
	4	$\overline{D2}$			
	5	$\overline{D3}$			
	6	$\overline{D4}$			
	7	$\overline{D5}$			
	8	$\overline{D6}$			
	9	$\overline{D7}$			
	10	DVOP (n)			
	11	$\overline{A0}$			
	12	\overline{AT}			
	13	$\overline{A2}$			
	14	$\overline{R/W}$			
	15	\overline{GRES}			
	16	ENA			
17	CLK	1 MHz clock			
	E~U	GND			

ANLG

CN No.	Pin No.	Signal Name	Remarks	I/O	Destination
6	1	COL X	Signal (X) to COL deflection amp	O	DEF
	A	2 V AC	Power supply for line power synchronization	I	
	2	COL Y	Signal (Y) to COL deflection amp	O	
	B	GND (2 V AC)		I	
	3	MAG RY1	Magnification changeover signal (1 : 10 detection resistance changeover)	O	
	C	GND			
	4	MAG RY2	Magnification changeover signal (1 : 100 shunt resistance changeover)	O	
	D	GND			
	5	CRT X	Signal (X) to CRT deflection amp	O	
	E	GND			
	6	WX (RPD) VR	VRs for adjusting CRT deflection width in full rapid mode	-	
	F	GND		-	
7	WX (RPD) VR	-			
H	GND				
8	WX (RPD) VR		-		
J	GND				
9	RPDT	Trigger signal of full-rapid deflection circuit	O		
K	GND				
10	-				
L	GND				
11	-				
M	GND				
12	RPD RY	Full-rapid changeover relay drive signal	O		

CN No.	Pin No.	Signal Name	Remarks	I/O	Destination		
6	N 13	GND PH RY	Photo CRT deflection ON/OFF relay drive signal	O	DEF		
	P 14	GND CRT Y				Signal (Y) to CRT deflection amp	O
	R 15	} GND	} Power input	}			
	S 16					} +15 V	
	T 17						} -15 V
	U						
26	1, 2	TV X	TV X scan signal	I	(Option) TV scan		
	3, 4	TV Y	TV Y scan signal	I			
	5	ETV	TV ON signal	O			
	6, E	+5 V	} Power supplies (for TV scan)	} O			
	7, F	-15 V					
	8, H	+15 V					
	9	TV ON					
	A~D	AG	(Unused) Analog GND	I			
	J, K, L	DG	Digital GND				
	23	1	X IN	Added to image shift (X)		I	(Option)
2		Y IN	Added to image shift (Y)	I			
3		—	} Power supply for optional accessory	} O			
4		—					
5		+15 V					
6		GND					
7		-15 V					
8	1	} GND	} Power input	} I	DEF (From S-6509)		
	A					} +15 V	
	2						} -15 V
	B						
	3						
	C	} ISY	} Image shift (Y)	} O			
	4						
	D	} ISX	} Image shift (X)	} O			
	5						
	E	DYF	Modulation signal input for dynamic focus	I			
	6	GAY	Gun alignment (Y)	O			
	F	GND	} Gun alignment (X)	} O			
	7	GAX					
	H	GND	} Stigmator (Y)	} O			
8	STIG Y						
J	GND	} Stigmator (X)	} O				
9	STIG X						
K	GND	} Dynamic focus coil drive signal for AFC	} O				
10	DYF REF						
L	+VREF	Reference voltage for lens (linked with \sqrt{HV})	O				

CN No.	Pin No.	Signal Name	Remarks	I/O	Destination
8	11	COND C	Reference voltage for 2nd condenser lens	O	DEF (From S-6509)
	M	-VREF	Reference voltage for lens (linked with \sqrt{HV})	O	
	12	COND F	Reference voltage for 1st condenser lens	O	
	N	GND*			
	13	OBJ	Reference voltage for objective lens	O	
25	P	GND*			
	1	X OUT		O	(Option) MDM unit
	2	X IN		I	
	3	Y OUT		O	
	4	Y IN		I	
	5	X	X scan signal output	O	
	6	Y	Y scan signal output	O	
	7	X0	X scan signal input	I	
	8	Y0	Y scan signal input	I	
	9	MY	Y } Manual shift signal	I	
	10	MX		X }	
	11	MSK	Signal for brightening dual-mag mask	I	
	12	} +15 V	} MDM unit drive signal		
	N				
	13				
P	} -15 V				
A~L		GND			
52	1	X OUT		O	(Option) S-6509
	2	X IN		I	
	3	Y OUT		O	
	4	Y IN		I	
	5	GND			
	6				
	7				
3			Refer to "DG circuit board"		DG
5	1	-VREF } GND }	Reference voltage output for condenser lens	O	Panel
	A				
	2	COND C	2nd condenser lens switch common	I	
	B				
	3	COND F	1st condenser lens VR center	I	
	C				
	4	} DYF VR	DYF signal	O	
	D		GND	O	
5	DYF VR center		I		
E					
6	+VREF	} Reference voltage output for image shift	O		
F	-VREF		O		

CN No.	Pin No.	Signal Name	Remarks	I/O	Destination	
5	7	STIG X	STIG X VR center	I	Panel	
	H	STIG Y	STIG Y VR center	I		
	8	F1	} Voltage to AFC ALIGNMENT VR	O		
	J	F2		O		
	9	S1	} Voltage to STIG ALIGNMENT VR	O		
	K	S2		O		
	10	S3		O		
	L	S4		O		
	11	IX	Image shift (X) VR center	I		
	M	AX	AFC ALIGN (X) VR center	I		
	12	SXX	STG ALIGN (XX) VR center	I		
	N	SYX	STG ALIGN (YX) VR center	I		
	13	IY	Image shift (Y) VR center.	I		
	P	AY	AFC ALIGN (Y) VR center	I		
	14	SXY	STG ALIGN (XY) VR center	I		
	R	SYY	STG ALIGN (YY) VR center	I		
	15	S				
	16	SE	SIG SELECT switch (CH1)	I		
	T					
	17	EXT	SIG SELECT switch (CH1)	I		
	U					
	18	EXT	SIG SELECT switch (CH2)	I		
	V					
	19	SE	SIG SELECT switch (CH2)	I		
	W	SW GND	SIG SELECT switch grounding (common)			
	20	} BRIGHT			Brightness VR	
	X					
	21					
	Y					
	22	} CONTRAST			Contrast VR	
	Z					
	23					
	A'					
	24	} ABC CONTRAST			ABC contrast VR (on panel inside cover)	
	B'					
	25					
	C'					
7			Refer to "VA circuit board"		VA	

PS

CN No.	Pin No.	Signal Name	Remarks	I/O	Destination
17	1	+24 V	} 10 kV HV power supply	O	HVC
	2	GND		O	
	3	} VAC RELAY	} Vacuum-linked (POST, HV) contact signal (contact closed under high vacuum)	O	
	4			O	
18	1	+24 V	} Vacuum-linked relay drive	} Specimen chamber open status-linked relay drive signal	Power supply sub-panel
	2	HIGH VAC			
	3	WINDOW OPEN			
	4	—	} 5 V power supply		
	5	—			
	6	+5 V			
	7	0			
51			Refer to circuit diagram of power supply (AC) for S-6540		(Option) S-6540
53			Refer to circuit diagram of power supply (AC) for S-6541		(Option) S-6541
15		AC input	Refer to "Circuit diagram"		Trans.
16		AC input	Refer to "Circuit diagram"		Trans.
14		DC PS output	Refer to "DEF circuit board"		DEF

PS sub-circuit board

CN No.	Pin No.	Signal Name	Remarks	I/O	Destination	
101	1	} 100 V AC	} 100 V AC input (after noise filter)	I I I I I I	Evacuation circuit board	
	2					
	3	GND	Ground line			
	4	+24 V	+24 V input (from evacuation circuit board)			
	5	VAC	Vacuum-linked relay drive signal			
	6	VALVE	Exchange chamber valve open relay signal			
102	1	} FAN	} 100 V AC for fan	O O O O O O O O O O I I		
	2					
	3	} TABLE TAP	} 100 V AC			} For table tap (unused)
	4					
	5					
	6	} HV	} 100 V AC			} For HV
	7					
	8	} 5 V PS	} 100 V AC			} For +5 V, 10 A power supply
	9					
	10		GND			
	11	+5 V	} +5 V			
	12	0				
18						

4-13 Table of I/O Addresses and Signal Functions

Address	Symbol	Function	Board Name										
\$8008	D0: INT. 0 D7: INT. 7	<u>INTERRUPT ENABLE</u> "0" : ENABLE "1" : MASK	DG										
\$8009	D0: INT. 0 D7: INT. 7	<u>INTERRUPT CLEAR</u> WRITE "1"											
\$8018	D0: A/M D1: EABC D2: EAFC D3: GAIN D4: EWM D5: D6: D7: EBU	<u>VIDEO AMP CONTROL</u> ABCC AUTO/MANUAL SELECTION "1" → AUTO ENABLE ABC "1" → ABCC ON (D0 = "1") ENABLE AFC "1" → AFC ON VIDEO GAIN SELECTION FOR AFC "0" → HIGH "1" → LOW ENABLE WAVEFORM B/C MONITOR ENABLE BRIGHT. UP (CROSS MARK) "1" → ON	ANLG										
\$8019	D0: $\overline{F1}$ D1: $\overline{F2}$ D2: $\overline{F3}$ D3: $\overline{F4}$ D4: $\overline{GM1}$ D5: $\overline{GM2}$ D6: \overline{POL} D7: \overline{CFVDO}	<u>VIDEO AMP CONTROL</u> <table style="display: inline-table; vertical-align: middle;"> <tr> <td>RAPID</td> <td>1111</td> </tr> <tr> <td>1 ms</td> <td>1110</td> </tr> <tr> <td>20 ms</td> <td>1100</td> </tr> <tr> <td>40 ms</td> <td>1000</td> </tr> <tr> <td>100 ms</td> <td>0000</td> </tr> </table> FILTER SELECTION GAMMA CONTROL "0" → ON POLARITY SELECTION "1" → NORMAL "0" → INVERT CRT FIXED VIDEO "0" → FIXED BRIGHT.		RAPID	1111	1 ms	1110	20 ms	1100	40 ms	1000	100 ms	0000
RAPID	1111												
1 ms	1110												
20 ms	1100												
40 ms	1000												
100 ms	0000												
\$801A	D0: $\overline{FS1}$ D1: $\overline{FS2}$ D2: D3: D4: \overline{RAPID} D5: \overline{SPKDIS} D6: \overline{EPMH} D7: \overline{EPCRT}	<u>VIDEO AMP CONTROL</u> EXPOSURE VALUE SELECTION FOR FILM SENSITIVITY FS1 → ×2 FS2 → × 1/2 BRIGHT. UP FOR RAPID SCAN "0" → ON SPOT KILLER "1" → ON ENABLE PHOTOMULTIPLIER HV "0" → ON ENABLE PHOTO. CRT "0" → PHOTO. CRT RASTER ON											
\$801B	SFVDO	CRT FIXED BRIGHT. SELECTION \$00 → -10 V, \$80 → 0 V, \$ +10 V (CHECK POINT → VIDEO AMP TP301)											
\$8020 21		DATA FOR VIDEO SIGNAL A/D CONVERTER											
\$8022 23 29		DATA FOR OBJ. LENS CURRENT CONTROL A/D CONVERTER											
\$8028		DATA FOR REFERENCE VOLTAGE OF LENS CIRCUITS A/D CONVERTER (LINKED WITH HIGH VOLTAGE) \$FC → 30 kV, \$CD → 20 kV, \$19 → 3 kV											

Address	Symbol	Function	Board Name
\$802A		SWEEP WAVEFORM WIDTH LINKED WITH HV AND MAG. IN STIG. MONIT. MODE LINKED WITH HV IN FILAMENT IMAGE MODE	ANLG
\$802D		DATA FOR A/D CONVERTER OF AUTO FOCUS CONTROL	
\$802E	D0: $\overline{LS0}$ D1: $\overline{LS1}$ D2: $\overline{LS2}$ D3: $\overline{LS3}$ D4: $\overline{LS4}$ D5: $\overline{LS5}$ D6: $\overline{LS6}$ D7:	LENS CONTROL } OBJ. LENS CURRENT SELECTION D0 = 0 } → LOWER STAGE D0 = 1 } → UPPER STAGE D1 = 1 } D1 = 0 } AUTO FOCUS FILAMENT IMAGE "0" → ON STIG. MONITOR "0" → ON } POLARITY SELECTION FOR AUTO FOCUS CURRENT 11: OFF, 10: +, 01: -, 00: PROHIBITION	
\$8030		DATA FOR X SCAN SPEED	
\$8031	D0: D1: D2: D3: D4: \overline{REDX} D5: \overline{REDY} D6: \overline{ECS} D7: \overline{ERAPID}	SWEEP GENERATOR CONTROL } RASTER LINES CONTROL 0011 → 128 LINES 1011 → 256 LINES 0101 → 512 LINES 1101 → 1024 LINES 1110 → 2048 LINES REDUCED AREA X SCAN "0" → ON REDUCE AREA Y SCAN "0" → ON ENABLE COSINE/SINE WAVEFORM "0" → SIN/COS ON ENABLE RAPID SCAN "0" → RAPID ON	
\$8032	D0: $\overline{S1}$ D1: \overline{ESYNC} D2: \overline{XRESET} D3: \overline{XFREE} D4: \overline{ESYNCY} D5: \overline{YRESET} D6: \overline{YFREE} D7: \overline{ETV}	SWEEP GENERATOR/MODE CONTROL X SPEED 1 ms "0" → ON SYNC. PULSE "1" → ON X SWEEP STOP "0" → ON NON SYNC. X "0" → ON Y SYNC. PULSE "0" → ON Y SWEEP STOP "0" → ON NON SYNC. Y "0" → ON ENABLE TV SCAN "0" → ON	
\$8033	D0: \overline{ESGX} D1: \overline{ESLX} D2: \overline{ESGY} D3: \overline{ESLY} D4: \overline{ESWY} D5: \overline{ENORM} D6: \overline{ESPLIT} D7: EXT	MODE CONTROL X SWEEP → X DEF 1/2 X SWEEP → X DEF Y SWEEP → Y DEF 1/2 Y SWEEP → Y DEF X3 Y SWEEP → Y DEF NORMAL SCAN SPLIT MODE ON EXT. SCAN SIGNAL → DEF	

Address	Symbol	Function	Board Name
\$8034		DATA FOR MAG. SELECTION DAC. LOWER DIGIT → HIGHER MAG.	ANLG
\$8035	D0: D1: D2: <u>EPH</u> D3: <u>CCRS</u> D4: <u>ESCANY</u> D5: <u>EWM1</u> D6: <u>EWM1</u> D7: <u>EWM3</u>	MODE CONTROL COL. DEF SHUNT RATIO "0" → X1, "1" → X1/100 COL. DEF REF. RESISTOR SELECTION "0" → 10 Ω, "1" → 1 Ω PHOTO CRT DEF ON "0" → ON SET CROSS MARK AT CRT CENTER "1" → ON Y SCAN NORM/W. FORM SELECTION "0" → ON WAVEFORM + VIDEO SIGNAL "0" → ON OBLIQUE + VIDEO SIGNAL "0" → ON VIDEO SIGNAL FOR FOCUS SEARCH ON "0" → ON ↓ CANCELED DC LEVEL	
\$8038	D0: D1: D2: D3: D4: D5: D6: D7:	DATA DISPLAY CONTROL CRT BOTTOM DATA INDICATION "1" → ON DARK BACKGROUND (BOTTOM) "1" → ON INPUT DATA INDICATION FROM KEY "1" → ON DARK BACKGROUND (INPUT DATA PART) "1" → ON } Y CLOCK SELECTION 00: 256 01: 1024 10: 512 11: 2048	DG
\$8039	D0: D1: D2: D3: D4: D5: D6: D7:	CLOCK SELECTION FOR DATA DISPLAY RAPID LOW ACTIVE X = 1 ms 20 ms 40 ms 100 ms 200 ms	
\$8040	D0: D1: D2: D3: D4: D5: D6: D7:	30 kV HV CONTROL } DATA FOR DAC (HV REFERENCE VOLTAGE) HV DATA X10 SELECTION "0" → X1, "1" → X10 HV ON "0" → OFF "1" → ON	
\$8041	D0: D1:	POST HV CONTROL LOWER POST ON "0" → OFF "1" → ON UPPER POST ON "0" → OFF "1" → ON	
\$8048		DATA FOR A/D CONVERTER OF AUTO STIGMA X CONTROL	
\$8049		DATA FOR A/D CONVERTER OF AUTOSTIGMA Y CONTROL	

4-14 Service Functions

The SYSTEM CHECK screen (called out by entering **CALL** **9**) displays functions 1 to 3. Besides, the functions 4, 5 and 7 are usable exclusively for service.

(1) Preliminary operations for using service function (coding)

- Set MAG PRESET 1 to 98.
- Set the upper 2 digits of the data number to 42.

CALL **2** **9** **8** **ENTER** **ENTER** **3** **4** **2** **ENTER**

(2) Display of adjustment frame on CRT

- A frame as shown at the right appears on the viewing CRT. It is usable for adjusting CRT distortion and amplitude, and data display width.
- Keyboard entry is **CALL** **9** **4** .
- Scan speed is selectable, though the LED display of each switch does not function.
- Upon pressing the **ENTER** key, the normal status is restored (the frame remains displayed).
- The frame can be erased by the same procedure as for erasing keyed-in data display (**CLR ALL**).

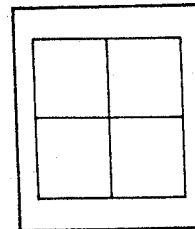

(3) Display of raster on photo CRT

- In the usual operating status, the raster does not appear unless photographing is started. This is inconvenient for adjustment. Therefore, the circuit is designed so as to enable forming the raster at the scan speed for image observation. (At the same time a frame similar to that in (2) above appears.)
- Keyboard entry is **CALL** **9** **5** .
- Usual status is restored by pressing the **ENTER** key.

(4) Display of software version

- The version numbers of the built-in programs can be read out.
- Keyboard entry is **CALL** **9** **7** .
- Usual status is restored by pressing the **ENTER** key.

(5) Use of magnification lower than minimum magnification

In the usual operating status, the minimum magnification depends on elements other than electrical capability (such as mechanical dimensions of electron-optical system). By performing (1) above, however, magnification can be reduced to the lowest level electrically possible with **MAG PRESET** switch. Although the lowest magnification obtainable by (1) does not differ widely from the usual minimum magnification at accelerating voltages of 20 kV or higher, the difference between them becomes conspicuous at lower accelerating voltages.

4-16 Check/Adjustment of Motor Drive Unit Components

4-16-1 Layout of Adjustment Variable Resistors and Check Terminals on Circuit Boards

Figure 4-17 shows the physical arrangement of adjustment variable resistors and check terminals mounted on the X CONT and Y CONT circuit boards.

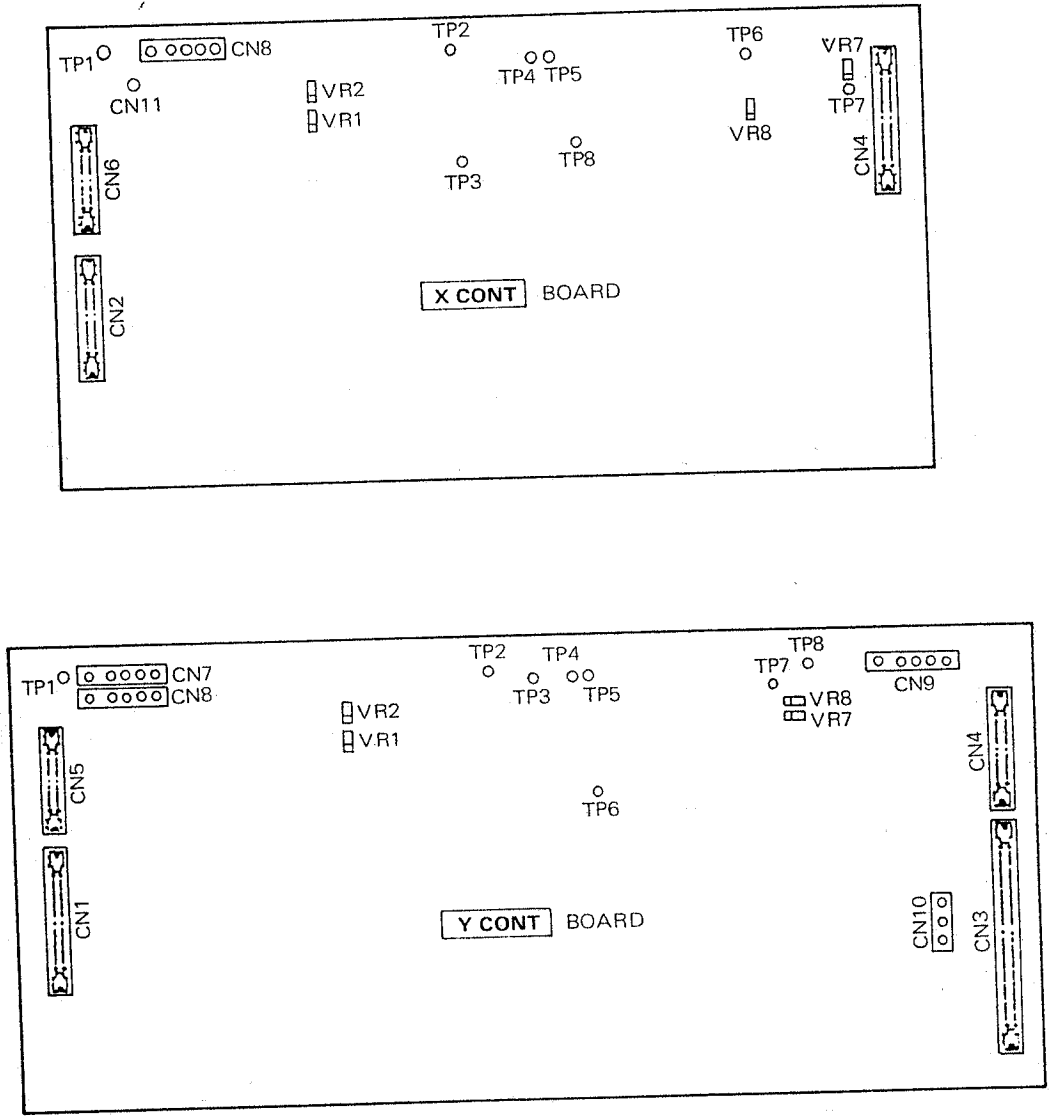

Fig. 4-17 Adjustment Variable Resistors and Check Terminals

4-16-2 Functions and Adjustment Procedures of Variable Resistors

(1) X CONT Circuit Board

VR No.	Function	Adjustment Procedure	Layout Diagram
VR1	Used for adjusting variable voltage to the center level (zero adjustment for IC6E).	Check a variable voltage range at TP5, and adjust voltage to the center level.	Fig. 4-17
VR2	Same as above	After adjustment of VR1, set voltage at TP5 to $0\text{ V} \pm 5\text{ mV}$.	Fig. 4-17
VR7	Used for adjusting movement speed of the specimen stage.	Adjust voltage at TP7 to $-1.95 \pm 0.1\text{ V}$, and then set time to 2 m/sec exactly.	Fig. 4-17
VR8	Same as above	Adjust voltage at TP6 to $+1.6 \pm 0.1\text{ V}$, and then set time to 2 m/sec exactly.	Fig. 4-17

(2) Y CONT Circuit Board

VR No.	Function	Adjustment Procedure	Layout Diagram
VR1	Used for adjusting variable voltage to the center level (zero adjustment for IC6E).	Check a variable voltage range at TP3, and adjust voltage to the center level.	Fig. 4-17
VR2	Same as above	After adjustment of VR1, set voltage at TP3 to $0\text{ V} \pm 5\text{ mV}$.	Fig. 4-17
VR7	Used for adjusting movement speed of the specimen stage.	Adjust voltage at TP8 to $-1.95 \pm 0.1\text{ V}$, and then set time to 2 m/sec exactly.	Fig. 4-17
VR8	Same as above	Adjust voltage at TP7 to $+1.6 \pm 0.1\text{ V}$, and then set time to 2 m/sec exactly.	Fig. 4-17

4-16-3 Voltages at Check Terminals

(1) Voltages on X CONT Circuit Board

Check Terminal	Function	Voltage Range	Remarks
TP1	Reference voltage	+5 V \pm 0.5 V	
TP2	Analog ground		
TP3	Motor speed control voltage	+1 V ~ +3 V	On overrun of the specimen stage, this voltage is forced to zero if it is attempted to move the stage further with the high-speed movement switch.
TP4	Same as above	-9.95 V ~ +9.95 V	
TP5	Mouse operation voltage	0 V \pm 9.95 V	
TP6	High-speed movement switch voltage	+1.6 V \pm 0.1 V	
TP7	Same as above	-1.95 V \pm 0.1 V	
TP8	Movement direction of specimen stage	'0' for rightward movement '1' for leftward movement	

(2) Voltages on Y CONT Circuit Board

Check Terminal	Function	Voltage Range	Remarks
TP1	Reference voltage	+5 V \pm 0.5 V	
TP2	Analog ground		
TP3	Mouse operation voltage	0 V \pm 9.95 V	
TP4	Motor speed control voltage	-9.95 V ~ +9.95 V	
TP5	Movement speed feedback voltage	\pm 15 V	
TP6	Motor speed control voltage	+1 V ~ +3 V	
TP7	High-speed movement switch voltage	+1.6 V \pm 0.1 V	
TP8	Same as above	-1.95 V \pm 0.1 V	

4-16-4 Motor Assembly

Specifications of Geared Motor Assembly

(1) RA3BA512S357-E15

(2) Composition

1) Geared Motor

- Rated voltage : 12 V DC
- No-load characteristic : 12 V DC, 365 mA or less
(at 20°C) 334 ±4 rpm
- Rated load characteristic : 12 V DC, 920 mA or less
(at 20°C) 267 ±40 rpm
- Allowable continuous load torque : 1.35 kg max.
- Maximum momentary torque : 5 kg-cm
- Gear ratio : 15
- Radial load : 2 kg or less
- Thrust load : 1.5 kg or less

2) Motor Drive

- Power requirement:
 - Control circuit : 5 to 15 V DC
 - Motor drive circuit : 0 to 12 V DC, 4 A max.
- Drive modes : Stopped when the START/STOP signal goes high (remains high in open stage).
Braked when the BRAKE signal goes low (remains high in open state).
Driven clockwise when the ROTATIONAL DIRECTION signal goes high (remains high in open state).

3) Encoder

- Signaling principle : Optical incremental signaling
- Output waveform : Rectangular pulse waveform
- Pulse count : 300 p/r
- Power supply voltage : 5 ±10 % V DC
- Power consumption : 80 mA or less
- Output voltage : $V_{OH} = 4.0 \text{ V min.}, I_{OH} = -450 \mu\text{A max.}$
 $V_{OL} = 0.5 \text{ V max.}, I_{OL} = 20 \text{ mA max.}$

(3) The output waveforms and output circuit scheme of encoder are shown on the next page.

RA3BA512S357-E15

ENCODER CIRCUIT

Output Waveforms

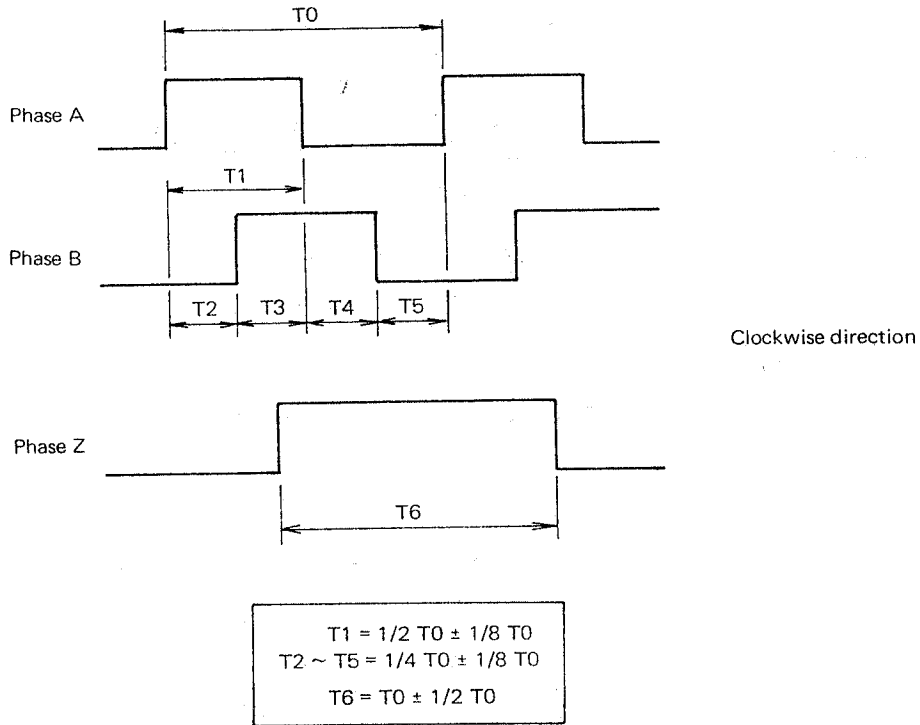

Output Circuit Scheme

(Output voltage: Standard type)

